

Demand-based ventilation | pressure-based control | AC fan 400 VAC | frequency inverter 4 kW 9,5 A Solution ID: AH-D-000008

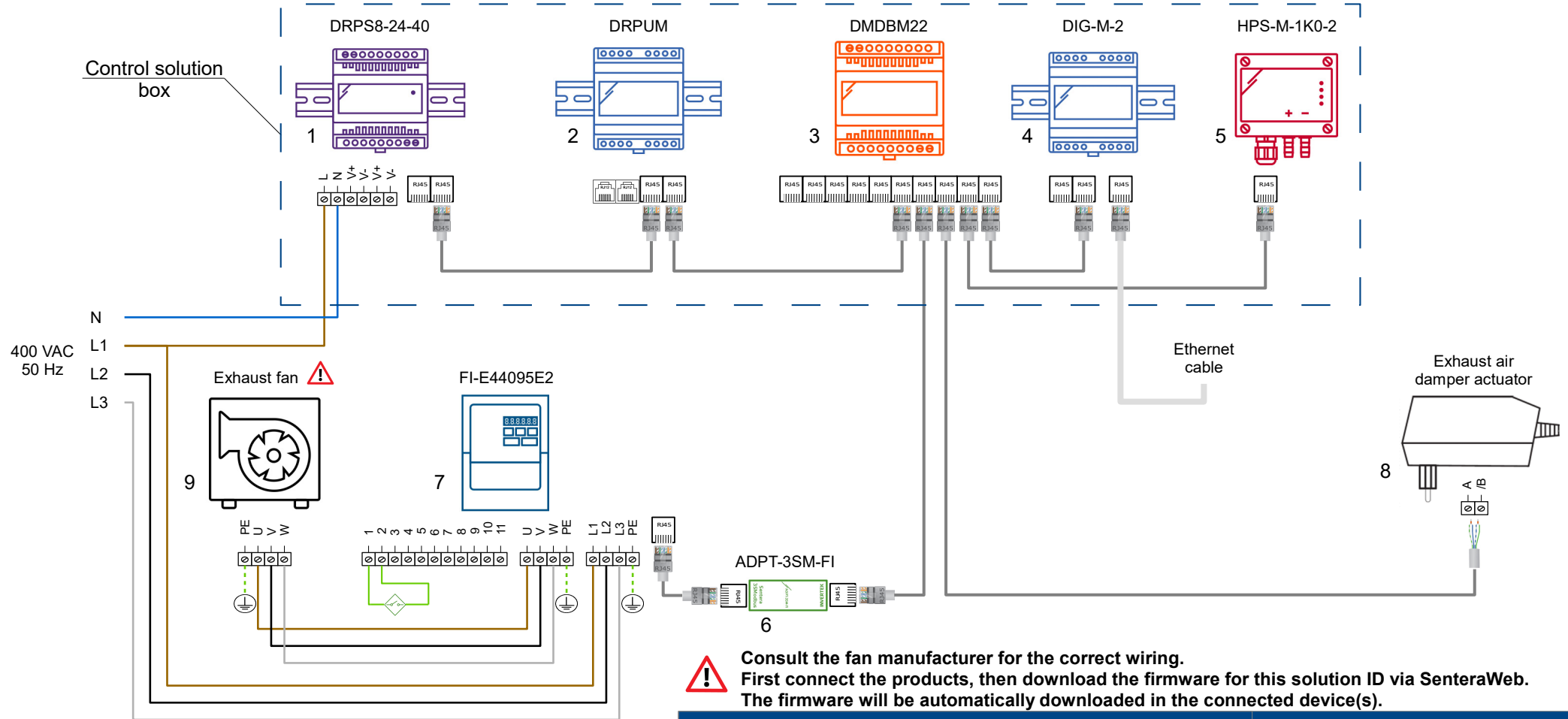

! Consult the fan manufacturer for the correct wiring.
 First connect the products, then download the firmware for this solution ID via SenteraWeb.
 The firmware will be automatically downloaded in the connected device(s).

Sentera products	External products
Article codes 1) DRPS8-24-40 2) DRPUM 3) DMDBM22 4) DIG-M-2 5) HPS-M-1K0-2 (PSET-PVC-200) 6) ADPT-3SM-FI 7) FI-E44095E2	8) Exhaust air damper actuator 9) Exhaust fan

This document is to be treated as an example or guideline only.
 Sentera bears no responsibility for any misprints, misinterpretations or mistakes in this document.
 Consult our disclaimer on <https://www.sentera.eu/>

AHU overview with control and measuring equipment

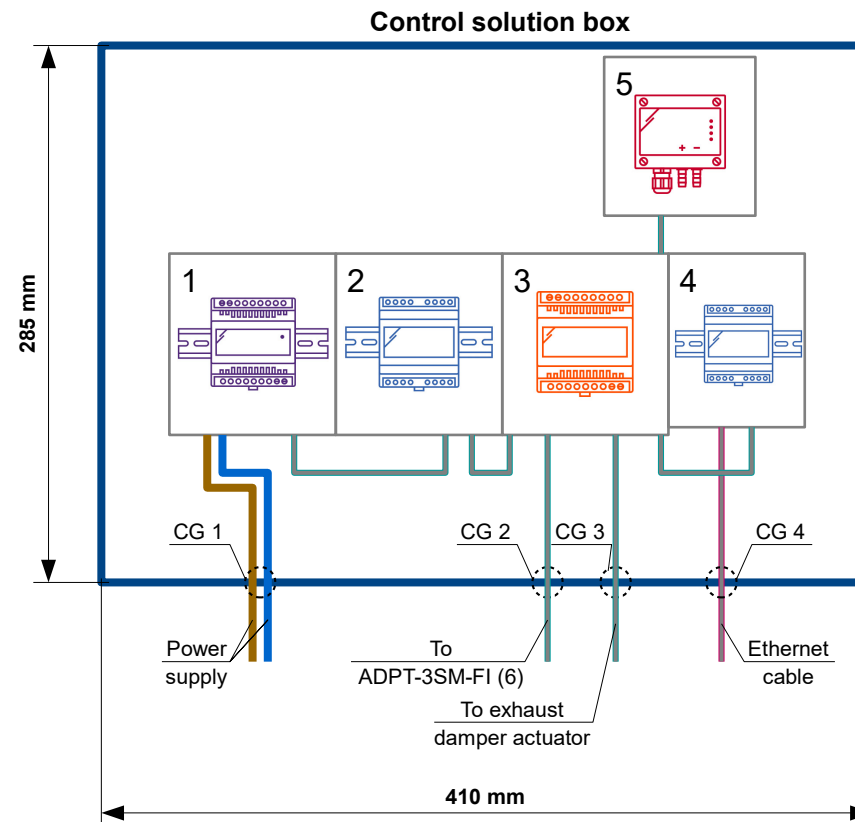
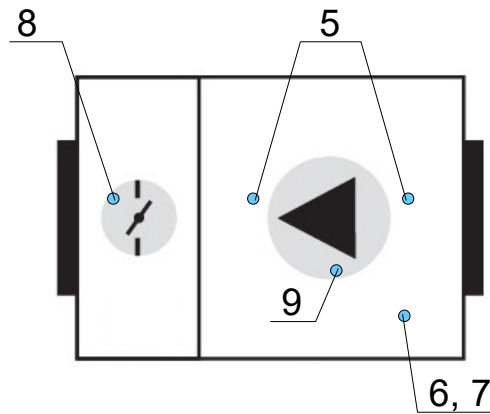

Consult the fan manufacturer for the correct wiring.
First connect the products, then download the firmware for this solution ID via SenteraWeb.
The firmware will be automatically downloaded in the connected device(s).

Article code / equipment type	Slave ID
Sentera products	
DIG-M-2	n/a (master device)
DRPUM	2
HPS-M-1K0-2	3
FI-E44095E2	4
External products	
Exhaust air damper actuator	5

Sentera products	External products
Article codes 1) DRPS8-24-40 2) DRPUM 3) DMDBM22 4) DIG-M-2 5) HPS-M-1K0-2 (PSET-PVC-200) 6) ADPT-3SM-FI 7) FI-E44095E2	8) Exhaust air damper actuator 9) Exhaust fan

This document is to be treated as an example or guideline only.
Sentera bears no responsibility for any misprints, misinterpretations or mistakes in this document.
Consult our disclaimer on <https://www.sentera.eu/>

Additional product mounting guidelines and explanations

All installations shall comply with local health and safety regulations and local electrical standards and approved codes. This product can only be installed by an engineer or a technician who has expert knowledge of the product and the safety precautions.

HPS-M-1K0-2, PSET-PVC-200

When installing PVC tubes, it's important to ensure proper sealing and secure connections to prevent air leakage, which could affect the accuracy of the pressure measurements. Additionally, the tubes should be installed in a way that minimizes bends and obstructions to maintain a smooth airflow path, ensuring reliable and consistent readings from the differential pressure sensor. Keeping the length of the tube to a minimum is preferable.

FI-E44095E2

The frequency inverter should be mounted in a vertical position only, ensuring it is securely placed on a flat, flame-resistant surface that is free from vibrations. Utilize the integral mounting holes or DIN Rail clip for proper installation. Additionally, it is crucial to provide a consistent flow of clean, moisture-free cooling air to meet the specific cooling requirements of the frequency inverter. This not only prolongs the lifespan of the inverter but also ensures optimal performance under varying conditions. Care should be taken to monitor and maintain the ambient temperature within the permissible limits to prevent any overheating issues.

The featured solution implies installation of the frequency inverters in the fan section of the AHU. The advantages of this approach are listed below:

Space Optimization. Integration within the AHU saves space by eliminating the need for an additional space in the electrical cabinet, making the overall setup more compact and efficient.

Reduced Cable Length. Direct integration within the AHU minimizes cable lengths, decreasing electrical losses and electromagnetic interference, thereby enhancing overall system efficiency.

Enhanced Control and Responsiveness. Proximity to the fan motor allows for more precise control, enabling better responsiveness to varying loads and improving energy efficiency by adjusting motor speed accurately.

Cost Efficiency. By eliminating the need for an external cabinet and associated components, direct integration might result in cost savings during installation and setup.

Conversely, frequency inverters can be installed in the electrical cabinet, however it presents certain considerations:

Heat Dissipation. In an enclosed cabinet, heat dissipation might become a concern, especially if the inverter generates significant heat during operation. Inadequate cooling or ventilation within the cabinet can lead to overheating issues, affecting the inverter's efficiency and lifespan.

Vibration and Shock. Vibrations and shocks from other electrical components within the cabinet or external factors can affect the inverter's stability and performance, potentially leading to malfunctions or reduced lifespan.

Interference and Noise. The presence of other electrical equipment in the cabinet might introduce electromagnetic interference, causing noise or interference that could affect the inverter's performance and reliability.

Complexity in Installation. Integrating the inverter within an electrical cabinet adds complexity to the installation process, requiring proper wiring, cable management, and ensuring compatibility with other components.



Consult the fan manufacturer for the correct wiring.

First connect the products, then download the firmware for this solution ID via SenteraWeb.

The firmware will be automatically downloaded in the connected device(s).

Article code / equipment type	Slave ID
Sentera products	
DIG-M-2	n/a (master device)
DRPUM	2
HPS-M-1K0-2	3
FI-E44095E2	4
External products	
Exhaust air damper actuator	5

Sentera products	External products
Article codes 1) DRPS8-24-40 2) DRPUM 3) DMDBM22 4) DIG-M-2 5) HPS-M-1K0-2 (PSET-PVC-200) 6) ADPT-3SM-FI 7) FI-E44095E2	8) Exhaust air damper actuator 9) Exhaust fan

This document is to be treated as an example or guideline only.

Sentera bears no responsibility for any misprints, misinterpretations or mistakes in this document.

Consult our disclaimer on <https://www.sentera.eu/>