

# SPV-8-010-CP

230 VAC POTENTIOMETER WITH  
MODBUS RTU AND DRY CONTACT

Mounting and operating instructions



## Table of contents

<b>SAFETY AND PRECAUTIONS</b>	<b>3</b>
<b>PRODUCT DESCRIPTION</b>	<b>4</b>
<b>ARTICLE CODES</b>	<b>4</b>
<b>INTENDED AREA OF USE</b>	<b>4</b>
<b>TECHNICAL DATA</b>	<b>4</b>
<b>STANDARDS</b>	<b>4</b>
<b>OPERATIONAL DIAGRAMS</b>	<b>5</b>
<b>WIRING AND CONNECTIONS</b>	<b>5</b>
<b>MOUNTING INSTRUCTIONS IN STEPS</b>	<b>5</b>
<b>OPERATING INSTRUCTIONS</b>	<b>8</b>
<b>TRANSPORT AND STORAGE</b>	<b>8</b>
<b>WARRANTY AND RESTRICTIONS</b>	<b>8</b>
<b>MAINTENANCE</b>	<b>8</b>

## SAFETY AND PRECAUTIONS

---



Read all the information, the datasheet, Modbus map, mounting and operating instructions and study the wiring and connection diagram before working with the product. For personal and equipment safety, and for optimum product performance, make sure you entirely understand the contents before installing, using, or maintaining this product.



For safety and licensing (CE) reasons, unauthorised conversion and /or modifications of the product are inadmissible.



The product should not be exposed to abnormal conditions, such as: extreme temperatures, direct sunlight or vibrations. Long-term exposure to chemical vapours in high concentration can affect the product performance. Make sure the work environment is as dry as possible; avoid condensation.



All installations shall comply with local health and safety regulations and local electrical standards and approved codes. This product can only be installed by an engineer or a technician who has expert knowledge of the product and safety precautions.



Avoid contacts with energised electrical parts. Always disconnect the power supply before connecting, servicing or repairing the product.



Always verify that you apply appropriate power supply to the product and use appropriate wire size and characteristics. Make sure that all the screws and nuts are well tightened and fuses (if any) are fitted well.



Recycling of equipment and packaging should be taken into consideration and these should be disposed of in accordance with local and national legislation / regulations.



In case there are any questions that are not answered, please contact your technical support or consult a professional.

## PRODUCT DESCRIPTION

The SPV-8-010-CP potentiometer is intended for stepless control of EC motors requiring a 0–10 VDC, 0–20 mA or 0–100 % PWM control signal. The minimum output values can be adjusted via Modbus within the ranges: 0–4 VDC / 0–8 mA / 0–40 % PWM and the maximum output values – within 6–10 VDC / 12–20 mA / 60–100 % PWM. In OFF position, the output is 0 VDC. It features dry contact for remote on / off switching of external equipment.

## ARTICLE CODES

Code	Supply voltage
SPV-8-010-CP	85–264 VAC / 50–60 Hz

## INTENDED AREA OF USE

- Speed control of EC fans in ventilation systems
- Control signal for AC fan speed controllers

## TECHNICAL DATA

- Modbus RTU communication
- Dry contact output
- Selectable output type: 0–10 VDC / 0–20 mA / 0–100 % PWM
- Infinitely variable control of the output voltage
- Control from low to high or from high to low speed, selectable via Modbus RTU
- OFF position
- Bootloader for updating the firmware via Modbus RTU
- Adjustable minimum (Vmin) and maximum (Vmax) output value via Modbus RTU
- Flush or surface mounting
- Enclosure:
  - ▶ External: ASA, white colour (28049P), IP54 (according to EN 60529)
  - ▶ Internal: polyamide, natural colour, IP44 (according to EN 60529)
- Operating ambient conditions:
  - ▶ temperature: 0–40 °C
  - ▶ rel. humidity: 5–95 % rH (non-condensing)

## STANDARDS

- Low Voltage Directive 2014/35/EU CE
  - ▶ EN 60529:1991 Degrees of protection provided by enclosures (IP Code) Amendment AC:1993 to EN 60529
  - ▶ EN 60730-1:2011 Automatic electrical controls for household and similar use - Part 1: General requirements
- EMC directive 2014/30/EU:
  - ▶ EN 60730-1:2011 Automatic electrical controls for household and similar use - Part 1: General requirements
  - ▶ EN 61000-6-1:2007 Electromagnetic compatibility (EMC) - Part 6-1: Generic standards - Immunity for residential, commercial and light industrial environments
  - ▶ EN 61000-6-3:2007 Electromagnetic compatibility (EMC) - Part 6-3: Generic standards - Emission standard for residential, commercial and light-industrial environments Amendments A1:2011 and AC:2012 to EN 61000-6-3
- WEEE Directive 2012/19/EU
- RoHs Directive 2011/65/EC

## OPERATIONAL DIAGRAMS

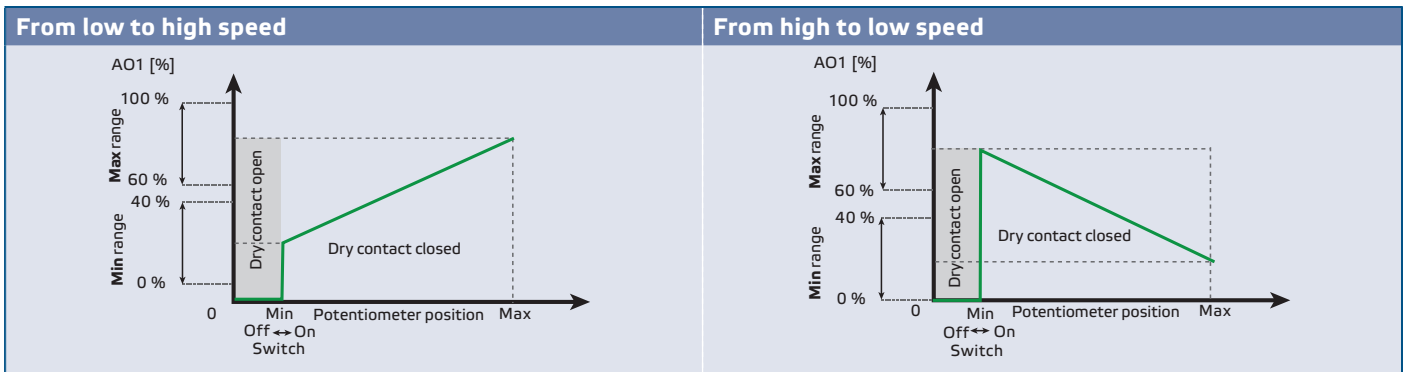

## WIRING AND CONNECTIONS

<b>L</b>	Power supply, line (85–264 VAC / 50–60 Hz)
<b>N</b>	Power supply, neutral (85–264 VAC / 50–60 Hz)
	Dry contact output that can be used to enable / disable the motor
<b>AO1</b>	Analogue / modulating output (0–10 VDC / 0–20 mA / PWM)
<b>GND</b>	Ground AO1
<b>A</b>	Modbus RTU (RS485), signal A
<b>/B</b>	Modbus RTU (RS485), signal /B
<b>Connections</b>	Cable cross section: 1,5 mm <sup>2</sup> ; pitch 3,5 mm

## MOUNTING INSTRUCTIONS IN STEPS

Before you start mounting the unit, read carefully **“Safety and Precautions”** and follow the steps:

### Flush mounting

1. Disconnect the mains supply.
2. Remove the knob by pulling it out.
3. Unscrew the washer to remove the cover of the external enclosure.
4. Do the wiring according to the wiring diagram (see **Fig. 1 Wiring and connections**).
5. Mount the internal enclosure into the wall according to the mounting dimensions shown in **Fig. 2 Mounting dimensions - flush mounting**.

**Fig. 1 Wiring and connections**

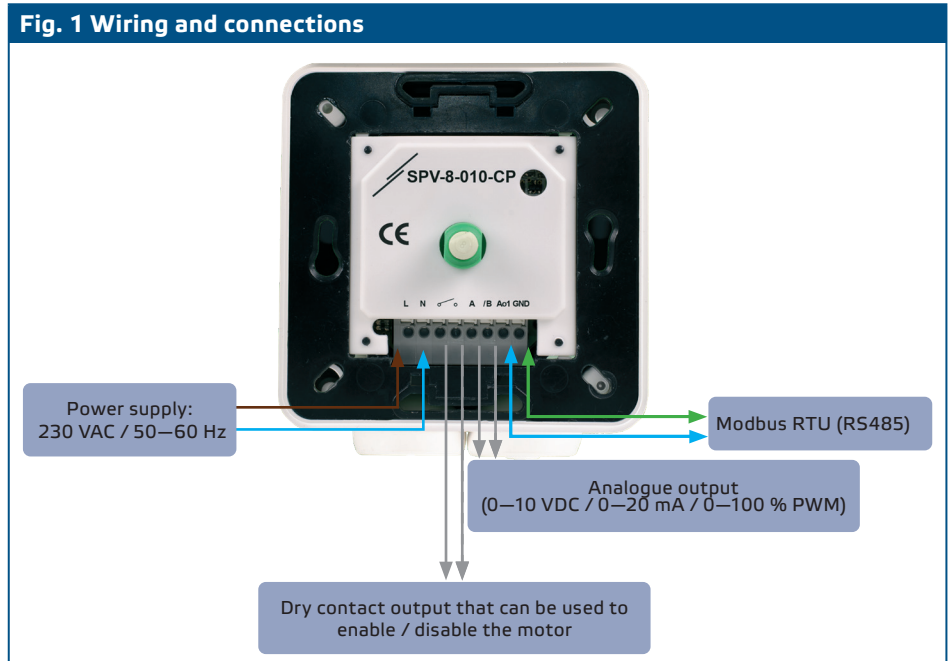

**Fig. 2 Mounting dimensions - flush mounting**

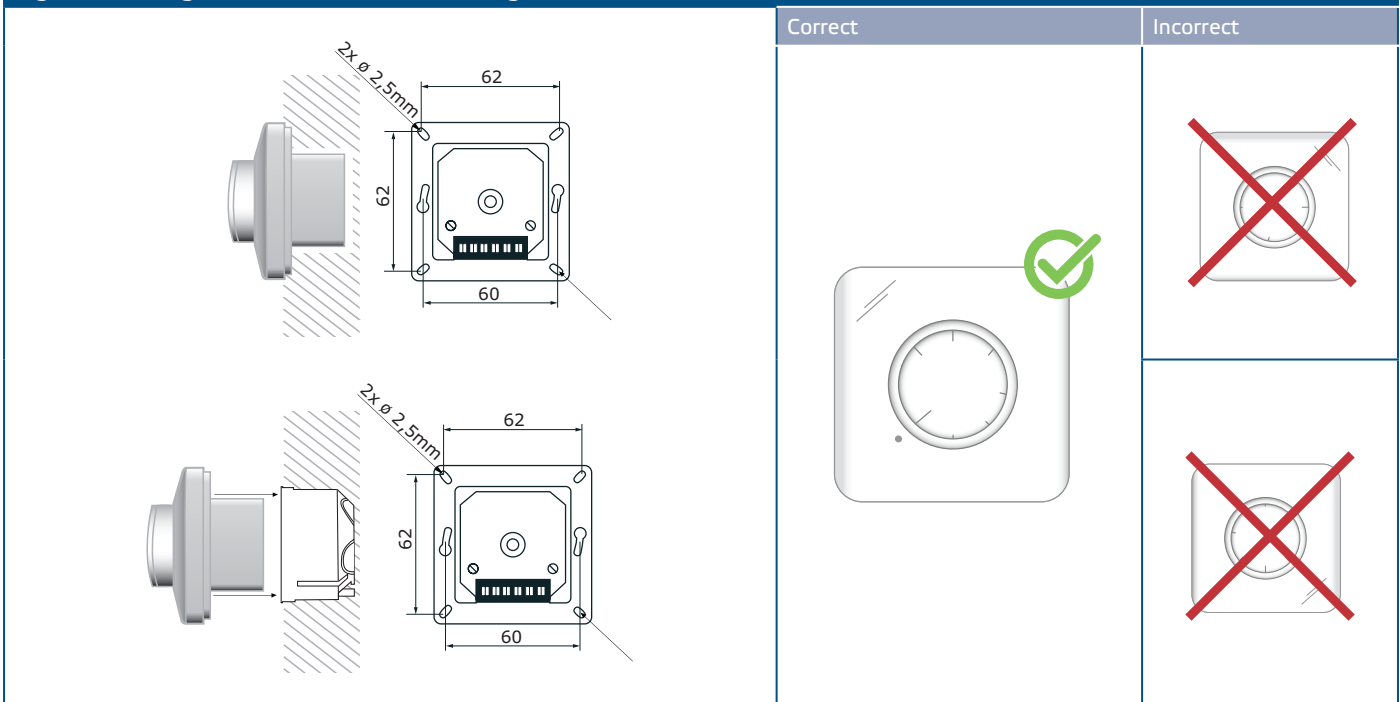

6. Mount back the cover and secure it with the washer.
7. Put back the knob and turn it to off position.
8. Turn on the power supply.
9. Customise the factory settings to the desired ones via the 3SModbus software or the Sensistant configurator. For the default factory settings, see the *Modbus register map*.

## Surface mounting

1. Disconnect the mains supply.
2. Remove the knob by pulling it out.
3. Unscrew the washer to remove the cover of the external enclosure.
4. Mount the external enclosure onto the surface by means of the screws and dowels adhering to the mounting dimensions shown in **Fig. 3 Mounting dimensions - surface mounting**.

**Fig. 3 Mounting dimensions - surface mounting**

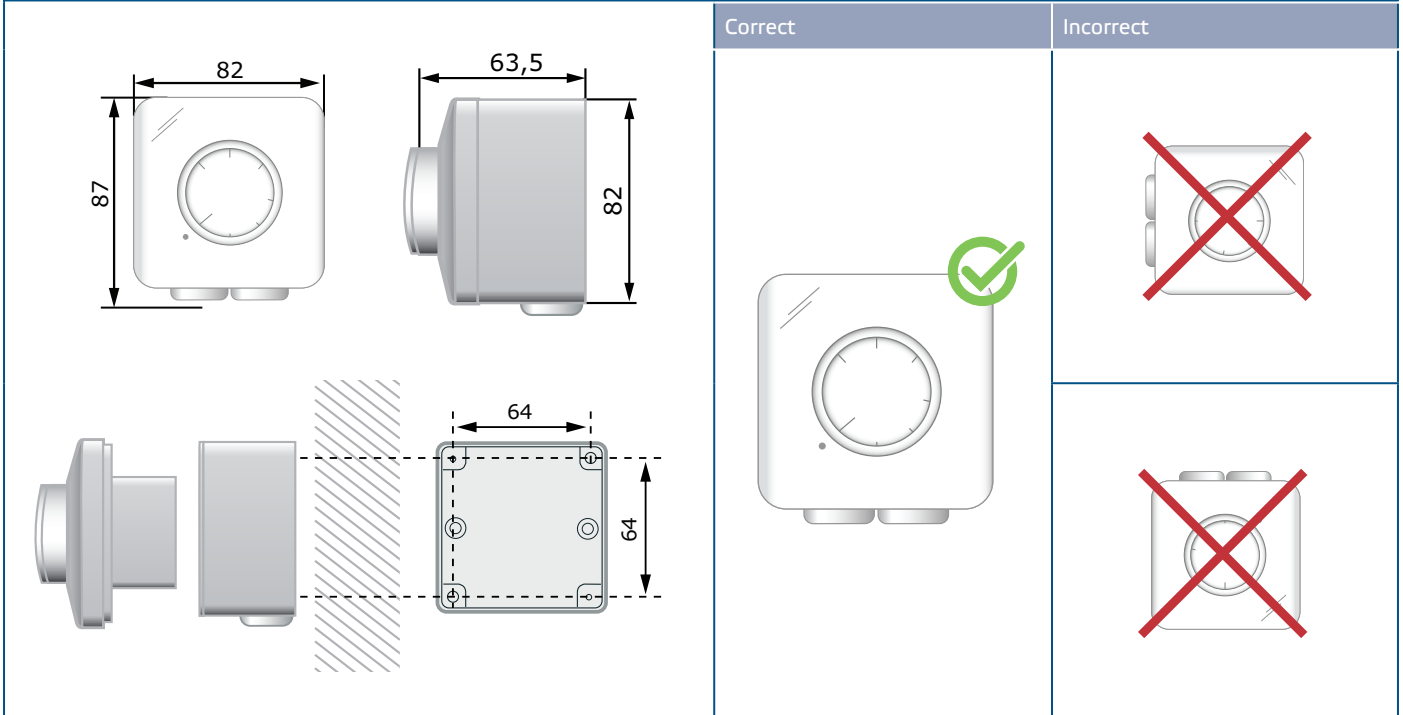

5. Insert the cables through the grommets.
6. Do the wiring according to the wiring diagram (see **Fig. 1 Wiring and connections**).
7. Insert the internal enclosure into the external one and fix it using the screws. Mount back the cover and secure it with the washer.
8. Put back the knob and turn it to off position.
9. Turn on the power supply.
10. Customise the factory settings to the desired ones via the 3SModbus software or the Sensistant configurator. For the default factory settings, see the *Modbus register map*.

## NOTE

For the complete Modbus register data, refer to the product Modbus Register Map, which is a separate document attached to the article code on the website and contains the registers list. Products with earlier firmware versions may not be compatible with this list.

## Optional settings

To assure correct communication, the NBT needs to be activated in only two devices on the Modbus RTU network. If necessary, enable the NBT resistor via 3SModbus or Sensistant (*Holding register 9*).

## Example 1

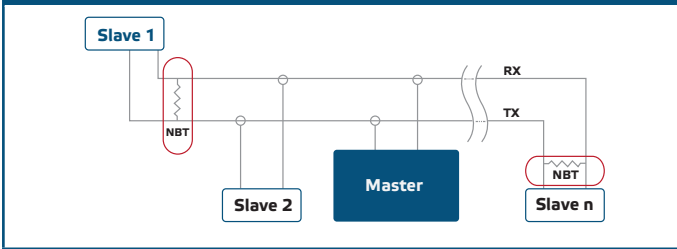

## Example 2

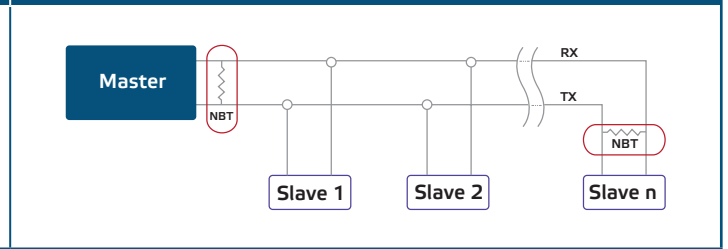

### NOTE

On a Modbus RTU network, two bus terminators (NBTs) need to be activated.

### NOTE

Mount the unit so that the terminal block and connections are at the lower side.

## OPERATING INSTRUCTIONS

### ATTENTION

Use only tools and equipment with non-conducting handles when working on electrical devices.

The unit is intended for use with EC fans / motors. It restarts after power failure.

**In case of faulty operation, please check if:**

- the right voltage is applied
- all connections are correct
- Modbus communication is working and all settings are accessible via Modbus RTU

## TRANSPORT AND STORAGE

Avoid shocks and extreme conditions; stock in original packing.

## WARRANTY AND RESTRICTIONS

Two years from the delivery date against defects in manufacturing. Any modifications or alterations to the product after the date of publication relieve the manufacturer of any responsibilities. The manufacturer bears no responsibility for any misprints or mistakes in this data.

## MAINTENANCE

In normal conditions this product is maintenance-free. If soiled, clean with a dry or damp cloth. In case of heavy pollution, clean with a non-aggressive product. In these circumstances the unit should be disconnected from the supply. Pay attention that no fluids enter the unit. Only reconnect it to the supply when it is completely dry.