

# SD

## ELECTRONIC FAN SPEED CONTROLLER

Mounting and operating instructions



# Table of contents

<b>SAFETY AND PRECAUTIONS</b>	<b>3</b>
<b>PRODUCT DESCRIPTION</b>	<b>4</b>
<b>ARTICLE CODES</b>	<b>4</b>
<b>INTENDED AREA OF USE</b>	<b>4</b>
<b>TECHNICAL DATA</b>	<b>4</b>
<b>STANDARDS</b>	<b>4</b>
<b>OPERATIONAL DIAGRAMS</b>	<b>5</b>
<b>WIRING AND CONNECTIONS</b>	<b>5</b>
<b>MOUNTING INSTRUCTIONS IN STEPS</b>	<b>5</b>
<b>OPERATING INSTRUCTIONS</b>	<b>7</b>
<b>TROUBLESHOOTING</b>	<b>7</b>
<b>TRANSPORT AND STORAGE</b>	<b>8</b>
<b>WARRANTY AND RESTRICTIONS</b>	<b>8</b>
<b>MAINTENANCE</b>	<b>8</b>

## SAFETY AND PRECAUTIONS

---



Read all the information in this manual, in the datasheet and in the Modbus Register Map before working with the product. For personal and equipment safety and for optimum product performance, make sure you fully understand the content before installing, using or servicing this product.



For safety and licensing (CE) reasons, unauthorised conversions and / or modifications of the product are inadmissible.



The product should not be exposed to abnormal conditions, such as extreme temperatures, direct sunlight or vibrations. Long-term exposure to chemical vapours in high concentration can affect the product performance. Make sure the work environment is as dry as possible and avoid condensation.



All installations must comply with local health and safety regulations and local electrical standards and approved codes. This product should only be installed by an engineer or a technician with expert knowledge of the product and safety precautions.



Avoid contact with energised electrical parts. Always disconnect the power supply before connecting, servicing or repairing the product.



Always check that you are connecting the correct power supply to the product and use wires of the correct characteristics and cross-section. Make sure all screws and nuts are properly tightened and fuses (if any) are in place.



Consideration should be given to recycling the equipment and packaging. These should be disposed of in accordance with local and national laws and regulations.



If there are questions that are not answered, contact your technical support or consult a professional.

## PRODUCT DESCRIPTION

These infinitely variable fan speed controllers allow you to manually adjust the rotational speed of single phase AC motors by varying the motor voltage through phase angle control. The integrated AC switch enables or disables the motor. The controller is suitable for both inset (IP44) and surface mounting (IP54).

## ARTICLE CODES

Output regulation from low to high	
Code	Current range [A]
<b>SDY-1-15-DT</b>	0,1–1,5
<b>SDY-1-30-DT</b>	0,2–3
Output regulation from high to low	
Code	Current range [A]
<b>SDX-1-15-DT</b>	0,1–1,5
<b>SDX-1-30-DT</b>	0,2–3

## INTENDED AREA OF USE

- Manual control of the motor / fan speed in HVAC applications
- For indoor use only

## TECHNICAL DATA

- Supply voltage: 230 VAC / 50–60 Hz
- Regulated output to motor:  $U_{min}-U_s$
- Unregulated output: 230 VAC / max. 2 A for connecting control indication, a valve or for 3-wire motor connection (auxiliary winding)
- Minimum speed adjustment by trimmer: 20–70 % of  $U_s$
- Speed control:
  - ▶ SDY—from low to high;
  - ▶ SDX—from high to low.
- Enclosure:
  - ▶ External: ASA, white colour (28049P), IP54 (according to EN 60529);
  - ▶ Internal: polyamide, black + white, IP44 (according to EN 60529).
- Operating ambient conditions:
  - ▶ temperature: 0–40 °C;
  - ▶ rel. humidity: 5–95 % rH (non-condensing).
- Storage temperature: -10–50 °C

## STANDARDS

- Low Voltage Directive 2014/35/EU CE
  - ▶ EN 60529:1991 Degrees of protection provided by enclosures (IP Code) Amendments A1:2000, A2:2013, AC:1993, AC:2016-12 and A2:2013/AC:2019-02 to EN 60529:1991.
- EMC directive 2014/30/EU
  - ▶ EN 61000-6-2:2005 Electromagnetic compatibility (EMC) - Part 6-2: Generic standards - Immunity for industrial environments Amendment AC:2005 to EN 61000-6-2:2005;
  - ▶ EN 61000-6-3:2007 Electromagnetic compatibility (EMC) - Part 6-3: Generic standards - Emission standard for residential, commercial and light-industrial environments Amendments A1:2011 and AC:2012 to EN 61000-6-3:2007;
  - ▶ EN 61000-3-2:2014 Electromagnetic compatibility (EMC) - Part 3-2: Limits - Limits for harmonic current emissions (equipment input current  $\leq 16$  A per phase).
- WEEE Directive 2012/19/EU
- RoHS Directive 2011/65/EU

## OPERATIONAL DIAGRAMS

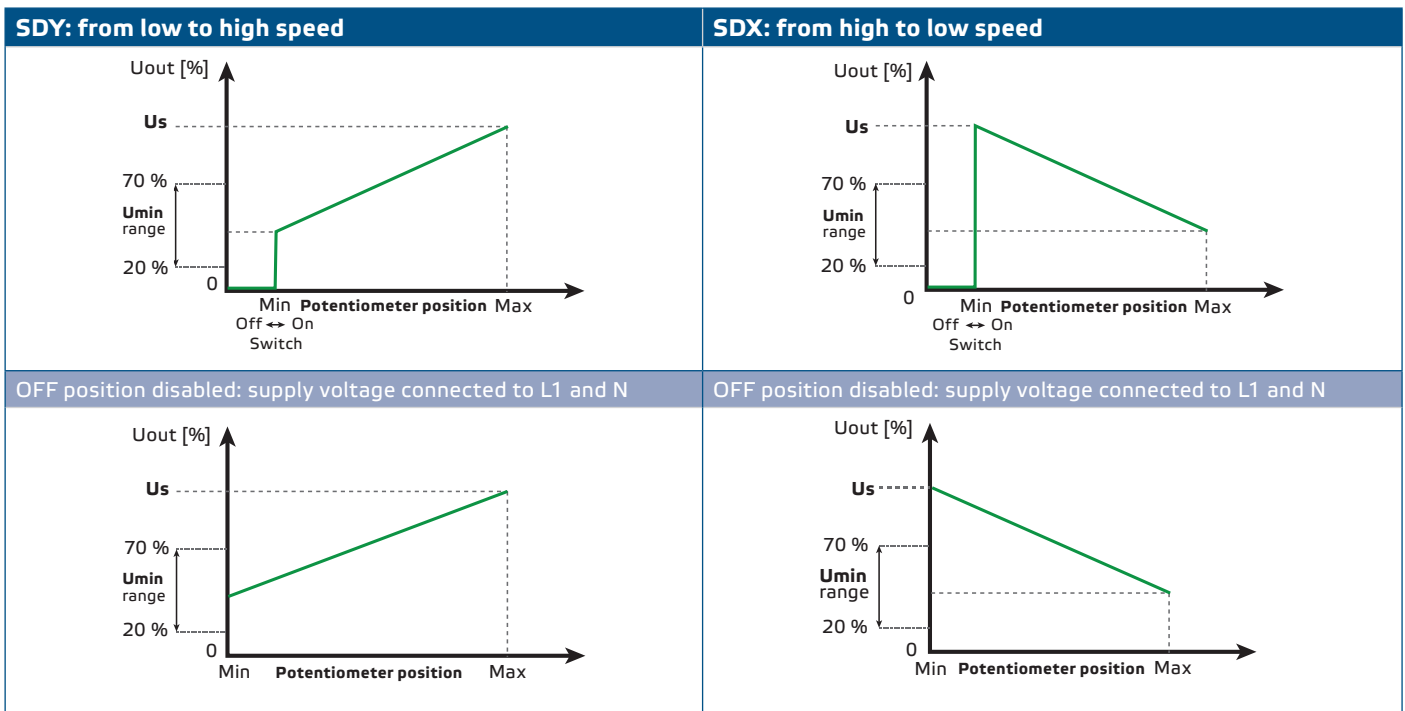

### **ATTENTION**

To disable the OFF position connect the 230 VAC supply voltage to the unregulated output (L1). In this case, do not connect the power supply to L.

## WIRING AND CONNECTIONS

<b>L</b>	Power supply, line (230 VAC ±10 % / 50–60 Hz)
<b>N</b>	Power supply, neutral
<b>L1</b>	Unregulated output, line (230 VAC ±10 % / 50–60 Hz, I <sub>max</sub> 2 A)
<b>N</b>	Unregulated output, neutral
<b>U2</b>	Regulated output to motor, neutral
<b>U1</b>	Regulated output to motor, line
<b>Connections</b>	Screw terminal block (6 poles), pitch 5 mm, cable cross section: 1,5 mm <sup>2</sup> , wire strip length max. 7 mm

## MOUNTING INSTRUCTIONS IN STEPS

Before you start mounting the unit, read carefully **“Safety and Precautions”** and follow these steps:

### Flush mounting

1. Disconnect the mains supply.
2. Remove the knob by pulling it out.
3. Unscrew the washer to remove the cover of the external enclosure.
4. Do the wiring according to the wiring diagram (see **Fig. 1** *Wiring and connections*).
5. Mount the internal enclosure into the wall according to the mounting dimensions shown in **Fig. 2** *Mounting dimensions - flush mounting*.

**Fig. 1 Wiring and connections**

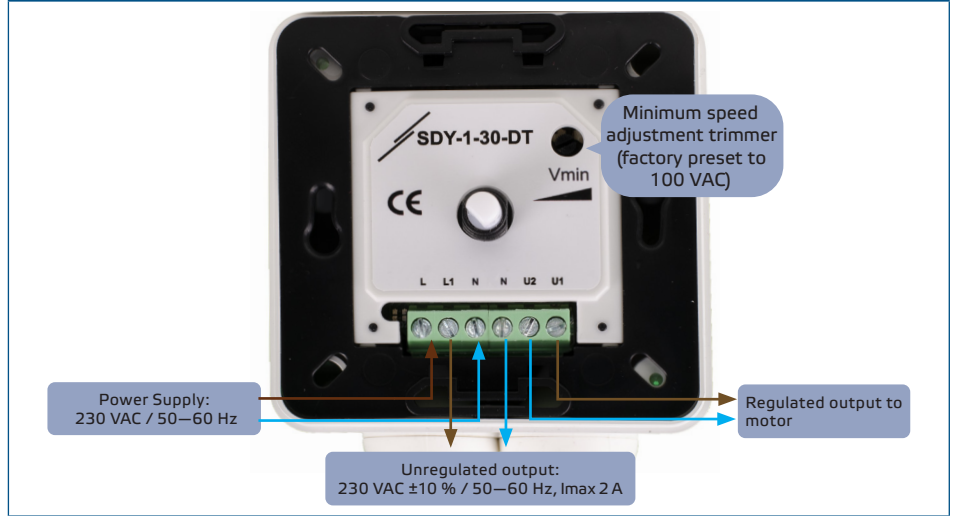

**Fig. 2 Mounting dimensions - flush mounting**

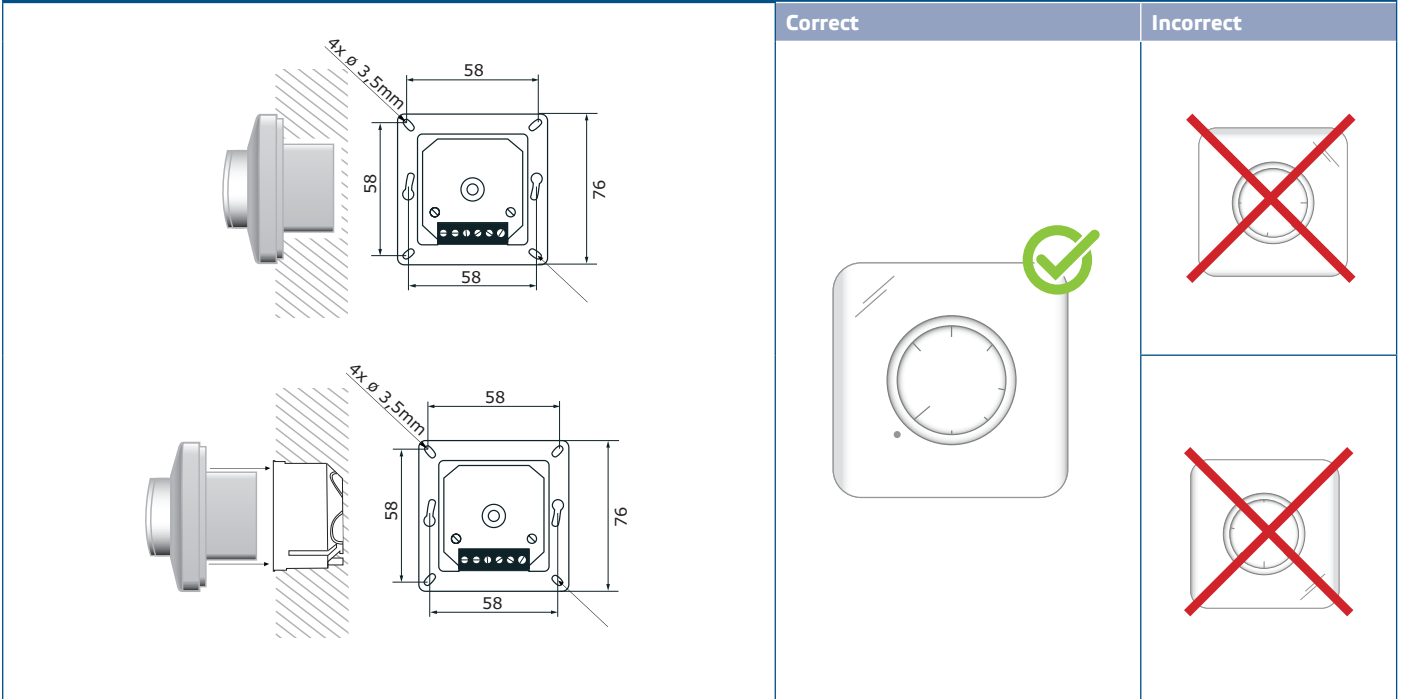

**NOTE**

*Mount the unit so that the terminal block and connections are at the lower side.*

- 6.** Adjust the Vmin trimmer in order to set the minimum speed. The factory setting is 100 VAC.
- 7.** Mount back the cover and secure it with the washer.
- 8.** Put back the knob and turn it to off position.
- 9.** Turn on the power supply.

**Surface mounting**

- 1.** Disconnect the mains supply.
- 2.** Remove the knob by pulling it out.
- 3.** Unscrew the washer to remove the cover of the external enclosure.
- 4.** Mount the external enclosure onto the surface by means of the screws and dowels adhering to the mounting dimensions shown in **Fig. 3 Mounting dimensions - surface mounting**.

**Fig. 3 Mounting dimensions - surface mounting**

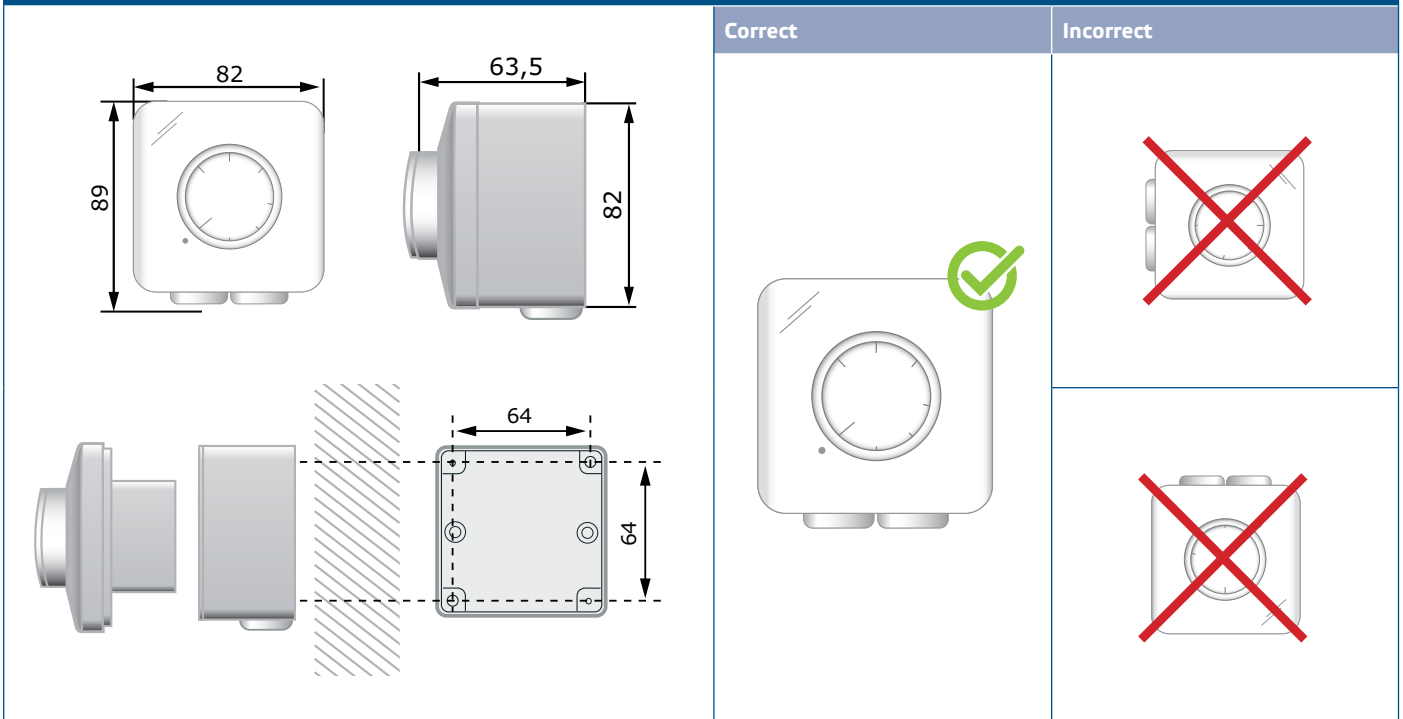

5. Insert the cables through the grommets.
6. Do the wiring according to the wiring diagram (see **Fig. 1 Wiring and connections**).
7. Insert the internal enclosure into the external one and fix it using the screws.

**NOTE**

*Mount the unit so that the terminal block and connections are at the lower side.*

8. Adjust the Vmin trimmer in order to set the minimum speed. The factory setting is 100 VAC.
9. Mount back the cover and secure it with the washer.
10. Put back the knob and turn it to off position.
11. Turn on the power supply.

**OPERATING INSTRUCTIONS**

**ATTENTION**

*Use only tools and equipment with non-conducting handles when working on electrical devices.*

The controller is to be used only with voltage controllable fans / motors. You can connect several motors to the controller as long as the current limit is not exceeded. The motor should be protected against overheating.

The minimum speed trimmer should be adjusted so that the motor cannot stall at minimum speed. The controller restarts after power failure.

**TROUBLESHOOTING**

In case of faulty operation, please check if:

- the right voltage is applied;
- the controller is not overheated;
- all connections are correct;
- the motor to be regulated is functioning.

## TRANSPORT AND STORAGE

---

Avoid shocks and extreme conditions; stock in original packing.

## WARRANTY AND RESTRICTIONS

---

Two years from the delivery date against defects in manufacturing. Any modifications or alterations to the product after the date of publication relieve the manufacturer of any responsibilities. The manufacturer bears no responsibility for any misprints or mistakes in this data.

## MAINTENANCE

---

In normal conditions this product is maintenance-free. If soiled, clean with a dry or damp cloth. In case of heavy pollution, clean with a non-aggressive product. In these circumstances the unit should be disconnected from the supply. Pay attention that no fluids enter the unit. Only reconnect it to the supply when it is completely dry.