

ODMHM-R | MULTIFUNCTIONAL TRANSMITTER FOR HARSH ENVIRONMENTS

Mounting and operating instructions



Table of contents

SAFETY AND PRECAUTIONS	3
PRODUCT DESCRIPTION	4
ARTICLE CODE	4
INTENDED AREA OF USE	4
TECHNICAL DATA	4
STANDARDS	4
OPERATIONAL DIAGRAMS	5
WIRING AND CONNECTIONS	5
MOUNTING & OPERATING INSTRUCTIONS IN STEPS	5
OPERATING INSTRUCTIONS	7
VERIFICATION OF INSTALLATION INSTRUCTIONS	8
TRANSPORT AND STORAGE	8
WARRANTY AND RESTRICTIONS	8
MAINTENANCE	8

SAFETY AND PRECAUTIONS



Read all the information, the datasheet, Modbus map, mounting and operating instructions and study the wiring and connection diagram before working with the product. For personal and equipment safety, and for optimum product performance, make sure you entirely understand the contents before installing, using or maintaining this product.



For safety and licensing (CE) reasons, unauthorised conversion and /or modifications of the product are inadmissible.



The product should not be exposed to abnormal conditions, such as extreme temperatures, direct sunlight or vibrations. Long-term exposure to chemical vapours in high concentration can affect the product performance. Make sure the work environment is as dry as possible; avoid condensation.



All installations shall comply with local health and safety regulations and local electrical standards and approved codes. This product can only be installed by an engineer or a technician who has expert knowledge of the product and safety precautions.



Avoid contacts with energised electrical parts. Always disconnect the power supply before connecting, servicing or repairing the product.



Always verify that you apply appropriate power supply to the product and use appropriate wire size and characteristics. Make sure that all the screws and nuts are well tightened and fuses (if any) are fitted well.



Recycling of equipment and packaging should be taken into consideration and these should be disposed of in accordance with local and national legislation / regulations.



In case there are any questions that are not answered, please contact your technical support or consult a professional.

PRODUCT DESCRIPTION

The ODMHHM-R are multifunctional transmitters which measure temperature, relative humidity, CO₂ level and ambient light, designed for applications in the agriculture industry. Based on these measurements, the dew-point temperature can be calculated. They are Power over Modbus supplied and all parameters and the output are accessible via Modbus RTU.

ARTICLE CODE

Article code	Supply	Connection	I _{max}
ODMHHM-R	24 VDC, PoM	RJ45	50 mA

INTENDED AREA OF USE

- Monitoring of temperature, relative humidity and CO₂ levels
- Suitable for harsh environments. Application field: greenhouses, livestock breeding farms, mushroom growing houses, horticulture, etc.

TECHNICAL DATA

- Suitable for harsh environments thanks to the special ammonia resistant coating
- Selectable temperature range: -30–70 °C
- Selectable relative humidity range: 0–100 %
- Selectable CO₂ range: 0–10.000 ppm
- Day / Night detection via ambient light sensor
- Ambient light sensor with adjustable 'active' and 'standby' level
- Removable CO₂ sensor element for easy calibration and verification
- Bootloader for updating the firmware via Modbus RTU communication
- Accuracy: ±0,4 °C (-30–70 °C); ±3 % rH (0–100 % rH); ±30 ppm CO₂ (0–10.000 ppm CO₂), depending on the selected parameter
- Enclosure material: POLYFLAM® RABS 90000 UV5, colour: gray RAL 7035
- Protection standard: IP65 (according to EN 60529)
- Operating ambient conditions:
 - ▶ temperature: -30–70°C
 - ▶ rel. humidity: 0–100 % rH, (non-condensing)
- Storage temperature: -10–60 °C

STANDARDS

- Low Voltage Directive 2014/35/EC CE
 - ▶ EN 60529:1991 Degrees of protection provided by enclosures (IP Code) Amendment AC:1993 to EN 60529
- EMC directive 2014/30/EC:
 - ▶ EN 61000-6-1:2007 Electromagnetic compatibility (EMC) - Part 6-1: Generic standards - Immunity for residential, commercial and light-industrial environments
 - ▶ EN 61000-6-3:2007 Electromagnetic compatibility (EMC) - Part 6-3: Generic standards - Emission standard for residential, commercial and light-industrial environments Amendments A1:2011 and AC:2012 to EN 61000-6-3
 - ▶ EN 61326-1:2013 Electrical equipment for measurement, control and laboratory use - EMC requirements - Part 1: General requirements
 - ▶ EN 61326-2-3:2013 Electrical equipment for measurement, control and laboratory use - EMC requirements - Part 2-3: Particular requirements - Test configuration, operational conditions and performance criteria for transducers with integrated or remote signal conditioning
 - ▶ High protective conformal coating
 - ▶ MIL-I-46058C qualified
 - ▶ PC-CC-830
- WEEE 2012/19/EC
- RoHS Directive (2011/65/EU) and EPA 33/50 compliant

OPERATIONAL DIAGRAMS

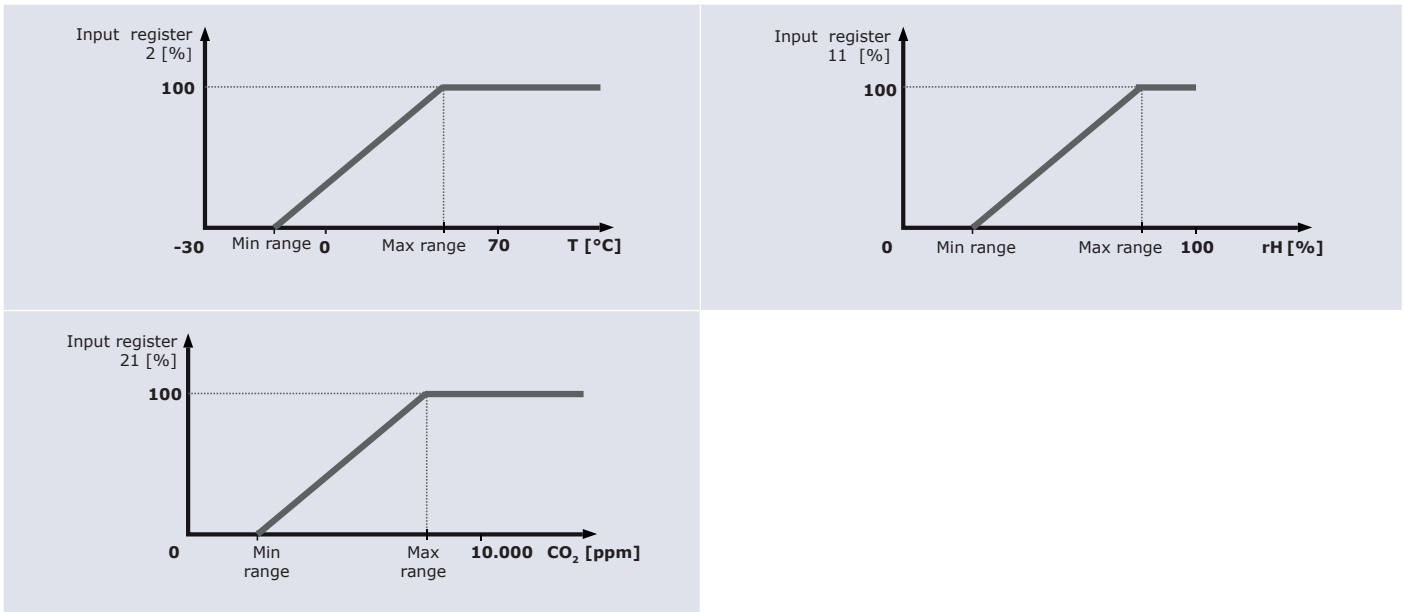

WIRING AND CONNECTIONS

RJ45 socket (Power over Modbus)		
Pin 1	24 VDC	Supply voltage
Pin 2		
Pin 3	A	Modbus RTU communication, signal A
Pin 4		
Pin 5	/B	Modbus RTU communication, signal /B
Pin 6		
Pin 7	GND	Ground, supply voltage
Pin 8		

MOUNTING & OPERATING INSTRUCTIONS IN STEPS

Before you start mounting the unit, read carefully **“Safety and Precautions”**. Choose a smooth surface for mounting location, preferably not directly exposed to the sun (e.g. the wall of a building facing north or north-west).

Follow these steps:

1. Unscrew the front cover of the enclosure and remove it.
2. Fix the enclosure onto the surface by means of suitable fasteners while adhering to the mounting dimensions shown in **Fig. 1 Mounting dimensions** and the correct mounting position shown in **Fig. 2 Mounting position**.

Fig. 1 Mounting dimensions

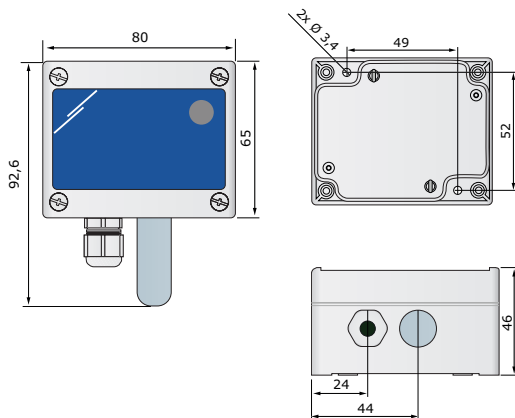
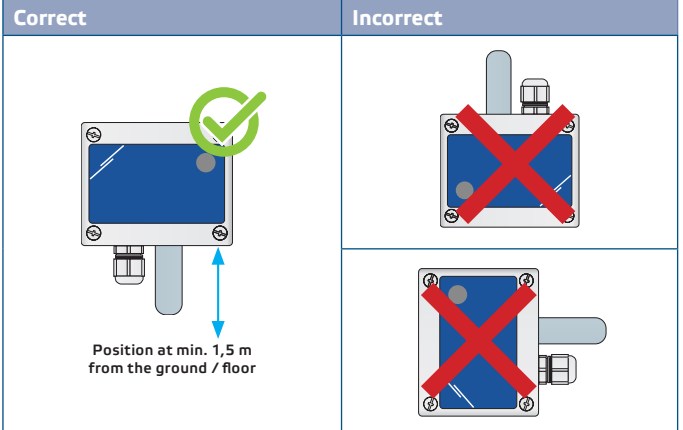
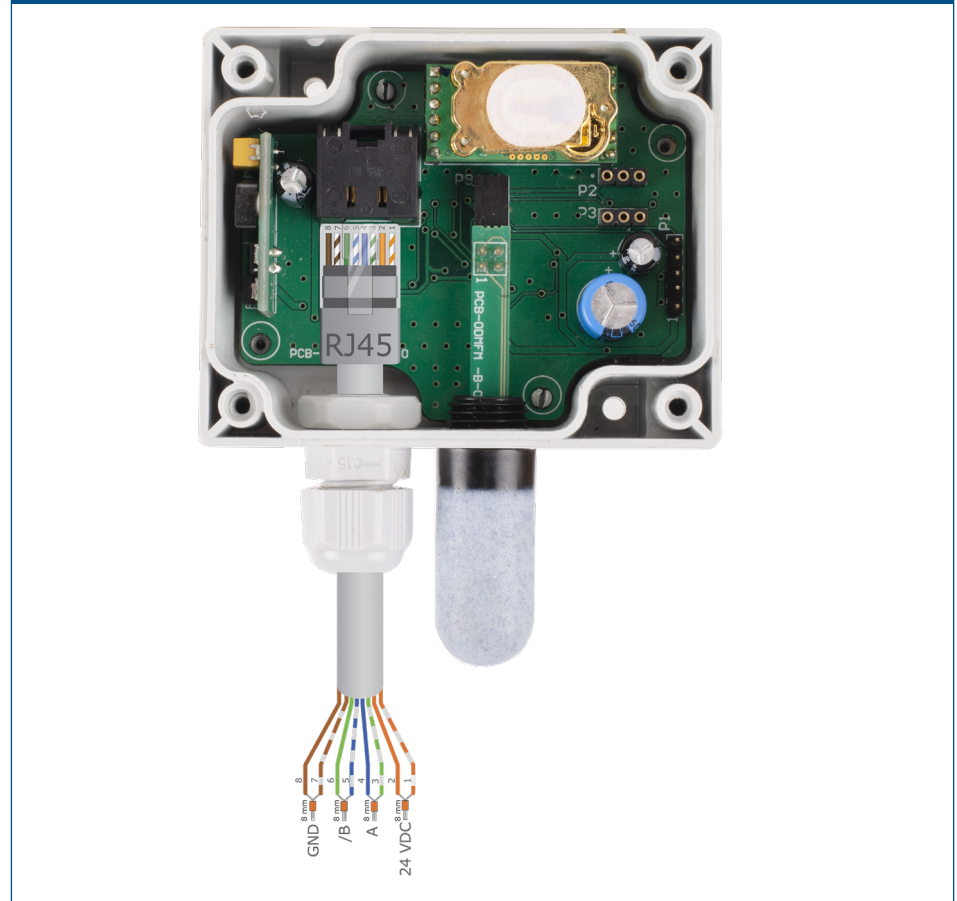

Fig. 2 Mounting position



3. Insert the cable through the cable gland, then crimp and plug it into the RJ45 socket as shown in **Fig. 3** below and the **Wiring and connections** section above.

Fig. 3 Connection



4. Close the enclosure and secure it with the screws. Tighten the cable gland to retain the IP rating of the enclosure.
5. Switch on the mains supply.
6. Customise the factory settings to the desired ones via SenteraWeb, 3SModbus software or Sensistant (if necessary). For the default factory settings, see the Modbus Register map of the product.

NOTE

For the complete Modbus register data, see the Modbus Register Map of the product. This is a separate document linked to the article code on the website containing the list of registers. Products with earlier firmware versions may not be compatible with this list.

Optional settings

To assure correct communication, the NBT needs to be activated in only two devices on the Modbus RTU network. If necessary, enable the NBT resistor via 3SModbus or Sensistant (Holding register 9).

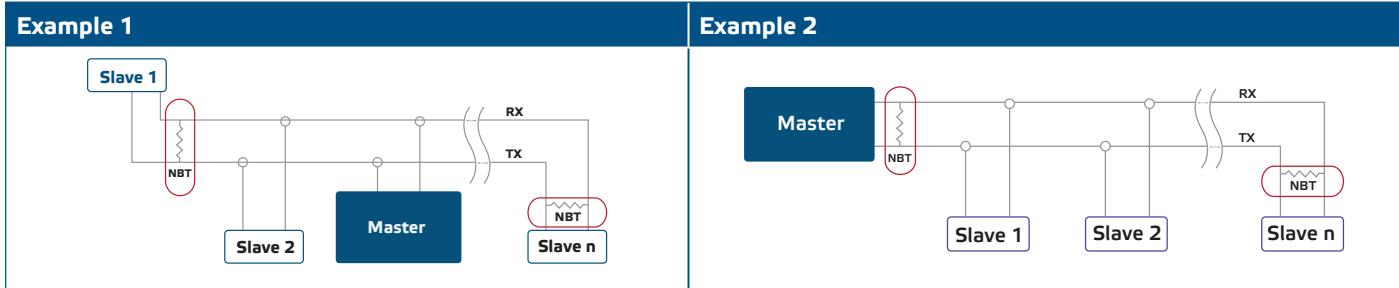

OPERATING INSTRUCTIONS

Calibration procedure

Sensor calibration is not necessary. All sensor elements are calibrated and tested in our factory. The CO2 sensor element is self-calibrating to compensate sensor drift. The ABC logic self-calibrating algorithm is by default enabled. This algorithm is designed to be used in applications where CO2 concentrations will drop to outside ambient conditions (400 ppm) at least one time (15 minutes) in a 7day period, which is typically seen during unoccupied periods. The sensor will reach its operational accuracy after 25 hours of continuous operation at a condition that it was exposed to ambient reference levels of air at 400 ppm ± 10 ppm CO2 . It is advisable to disable the self-calibrating algorithm in situations where the CO2 level will not drop to 400 ppm during the above described timespan. In the unlikely event of CO2 sensor element failure, this component can be replaced.

Firmware update

New functionalities and bug fixes are made available via a firmware update. In case your device does not have the latest firmware installed, it can be updated. SenteraWeb is the easiest way to update the firmware of the unit. In case you do not have an internet gateway available, the firmware can be updated via the 3SM boot application (part of the Sentera 3SMcenter software suite).

NOTE

Make sure the power supply does not get interrupted during the "bootload" procedure.

Ambient light sensor

The measured light intensity in lux is available in Input Register 41. Additionally, an active and standby level can be defined in Holding registers 35 and 36. Input Register 42 indicates if the measured value is below standby level, above active level or in between both levels:

- Ambient light level < standby level: Input Register 42 indicates "Standby".
- Ambient light level > active level: Input Register 42 indicates "Active".
- Standby level < Ambient light level < Active level: Input Register 42 indicates "Low intensity".

VERIFICATION OF INSTALLATION INSTRUCTIONS

If your device does not function as expected, please check the connections.

TRANSPORT AND STORAGE

Avoid shocks and extreme conditions; stock in original packing.

WARRANTY AND RESTRICTIONS

Two years from the delivery date against defects in manufacturing. Any modifications or alterations to the product after the date of publication relieve the manufacturer of any responsibilities. The manufacturer bears no responsibility for any misprints or mistakes in this data.

MAINTENANCE

In normal conditions this product enclosure is maintenance-free. If soiled, clean with a dry or damp cloth. In case of heavy pollution, clean with a non-aggressive product. The sensor element protector is made from porous material and, when exposed to extreme climate conditions such as dust, water and wind, may become clogged. This may result in faulty measurements. Please clean with mild non-acidic detergent. In these circumstances the unit should be disconnected from the supply. Pay attention that no fluids enter the unit. Only reconnect it to the supply when it is completely dry.