

OCTHM-R | INTELLIGENT TEMPERATURE AND HUMIDITY SENSOR

Mounting and operating instructions



Table of contents

SAFETY AND PRECAUTIONS	3
PRODUCT DESCRIPTION	4
ARTICLE CODE	4
INTENDED AREA OF USE	4
TECHNICAL DATA	4
STANDARDS	4
OPERATIONAL DIAGRAMS	5
WIRING AND CONNECTIONS	5
MOUNTING & OPERATING INSTRUCTIONS IN STEPS	6
OPERATING INSTRUCTIONS	7
VERIFICATION OF INSTALLATION INSTRUCTIONS	8
TRANSPORT AND STORAGE	8
WARRANTY AND RESTRICTIONS	8
MAINTENANCE	8

SAFETY AND PRECAUTIONS



Read all the information, the datasheet, Modbus map, mounting and operating instructions and study the wiring and connection diagram before working with the product. For personal and equipment safety, and for optimum product performance, make sure you entirely understand the contents before installing, using or maintaining this product.



For safety and licensing (CE) reasons, unauthorised conversion and /or modifications of the product are inadmissible.



The product should not be exposed to abnormal conditions, such as extreme temperatures, direct sunlight or vibrations. Long-term exposure to chemical vapours in high concentration can affect the product performance. Make sure the work environment is as dry as possible; avoid condensation.



All installations shall comply with local health and safety regulations and local electrical standards and approved codes. This product can only be installed by an engineer or a technician who has expert knowledge of the product and safety precautions.



Avoid contacts with energised electrical parts. Always disconnect the power supply before connecting, servicing or repairing the product.



Always verify that you apply appropriate power supply to the product and use appropriate wire size and characteristics. Make sure that all the screws and nuts are well tightened and fuses (if any) are fitted well.



Recycling of equipment and packaging should be taken into consideration and these should be disposed of in accordance with local and national legislation / regulations.



In case there are any questions that are not answered, please contact your technical support or consult a professional.

PRODUCT DESCRIPTION

The OCTHM-R are intelligent sensors featuring adjustable temperature and relative humidity ranges suitable for outdoor applications or tough environments. Their algorithm generates an output value based on the measured temperature and relative humidity values, which can be used to directly control an EC fan, an AC fan speed controller or an actuator powered damper. They are Power over Modbus supplied and all parameters are accessible via Modbus RTU communication.

ARTICLE CODE

Article code	Supply	Connection	I _{max}
OCTHM-R	24 VDC, PoM	RJ45	25 mA

INTENDED AREA OF USE

- Demand controlled ventilation based on temperature and relative humidity
- Suitable for both indoor and outdoor use (e.g. open-air spaces, multi-storey and subterranean car parks, residential and commercial buildings)

TECHNICAL DATA

- Wiring via RJ45 connector
- Selectable temperature range: -30–70 °C
- Selectable relative humidity range: 0–100 % rH
- Accuracy:
 - ▶ ± 0,4 °C (range -30–70 °C)
 - ▶ ± 3% rH (range 0–100 %)
- Ambient light sensor with adjustable 'active' and 'standby' level
- Enclosure material: POLYFLAM® RABS 90000 UV5, colour: gray RAL 7035
- Protection standard: IP65 (according to EN 60529)
- Operating ambient conditions:
 - ▶ Temperature: -30–70°C
 - ▶ Rel. humidity: 0–100 % rH, (non-condensing)
- Storage temperature: -10–60 °C

STANDARDS

- Low Voltage Directive 2014/35/EC CE
 - ▶ EN 60529:1991 Degrees of protection provided by enclosures (IP Code) Amendment AC:1993 to EN 60529
- EMC directive 2014/30/EC
 - ▶ EN 61000-6-1:2007 Electromagnetic compatibility (EMC) - Part 6-1: Generic standards - Immunity for residential, commercial and light-industrial environments
 - ▶ EN 61000-6-3:2007 Electromagnetic compatibility (EMC) - Part 6-3: Generic standards - Emission standard for residential, commercial and light-industrial environments Amendments A1:2011 and AC:2012 to EN 61000-6-3
 - ▶ EN 61326-1:2013 Electrical equipment for measurement, control and laboratory use - EMC requirements - Part 1: General requirements
 - ▶ EN 61326-2-3:2013 Electrical equipment for measurement, control and laboratory use - EMC requirements. Part 2-3: Particular requirements - Test configuration, operational conditions and performance criteria for transducers with integrated or remote signal conditioning
- WEEE 2012/19/EC
- RoHs Directive 2011/65/EC

OPERATIONAL DIAGRAMS

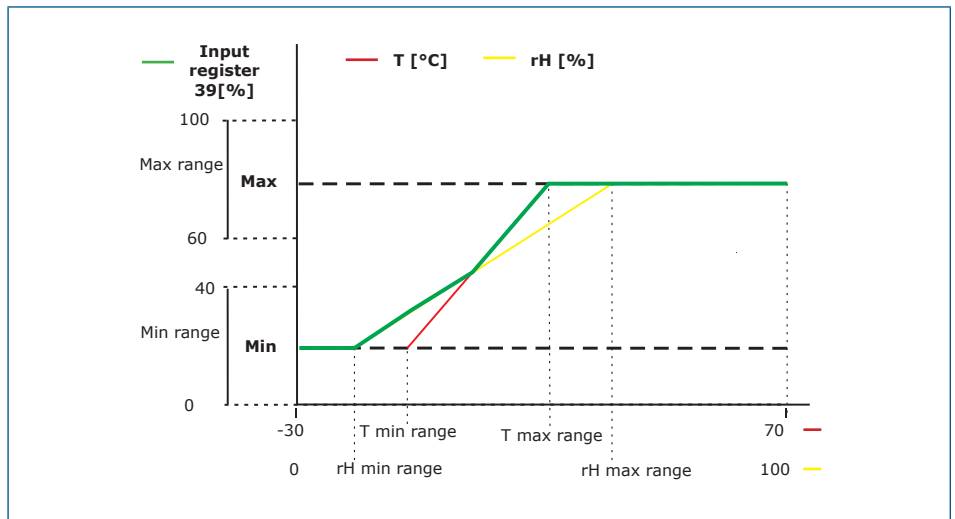

NOTE

The output changes automatically depending on the highest T or rH value, i.e. the highest of the two values controls the output. See the green line in the operational diagram above. One or multiple sensors can be deactivated. E.g. it is also possible to control the output based on the measured rH value only.

WIRING AND CONNECTIONS

RJ45 socket (Power over Modbus)		
Pin 1	24 VDC	Supply voltage
Pin 2		
Pin 3	A	Modbus RTU communication, signal A
Pin 4		
Pin 5	/B	Modbus RTU communication, signal /B
Pin 6		
Pin 7	GND	Ground, supply voltage
Pin 8		

MOUNTING & OPERATING INSTRUCTIONS IN STEPS

Before you start mounting the unit, read carefully **“Safety and Precautions”**. Choose a smooth surface for mounting location, preferably not directly exposed to the sun (e.g. the wall of a building facing north).

Follow these steps:

1. Unscrew the front cover of the enclosure and remove it.
2. Fix the enclosure onto the surface by means of suitable fasteners while adhering to the mounting dimensions shown in **Fig. 1 Mounting dimensions** and the correct mounting position shown in **Fig. 2 Mounting position**.

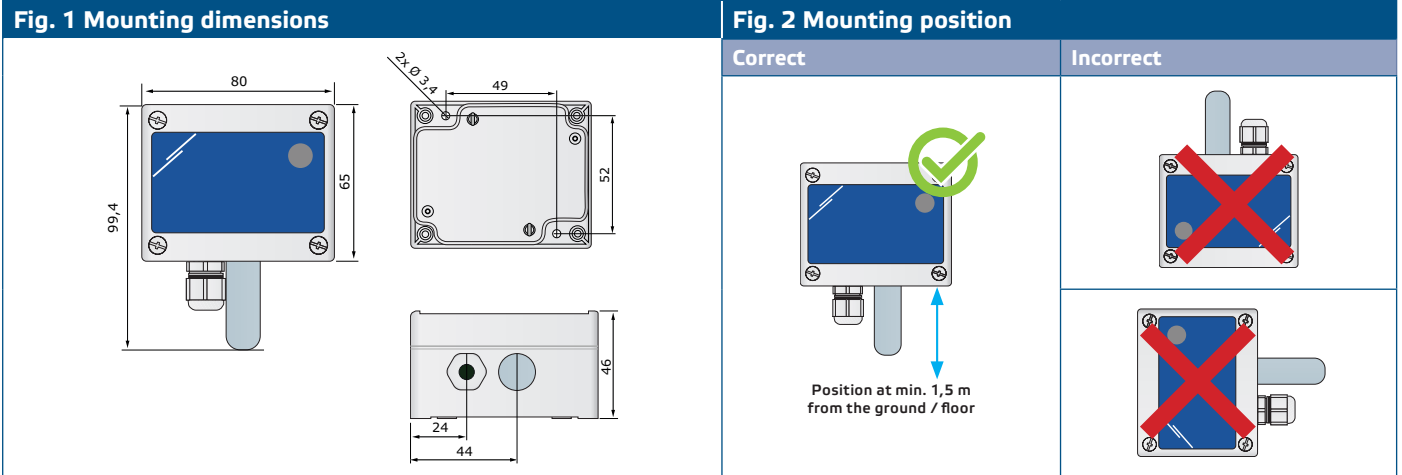

3. Insert the cable through the cable gland, then crimp and plug it into the RJ45 socket as shown in **Fig. 3** below and the **Wiring and connections** section above.

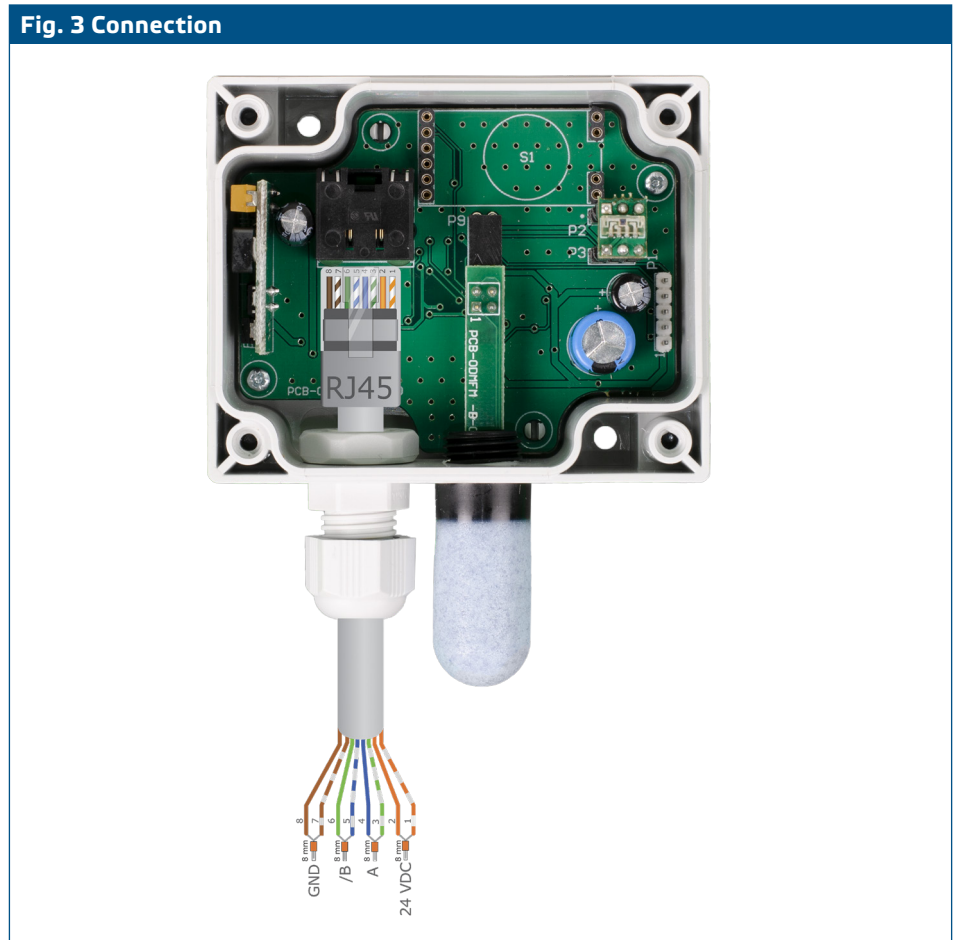

4. Put back the cover and secure it with the screws.
5. Switch on the power supply.
6. Customise the factory settings to the desired ones via the 3SModbus software or the Sensistant configurator. For the default factory settings, see the *Modbus register map* of the product.

NOTE

For the complete Modbus register data, see the Modbus Register Map of the product. This is a separate document linked to the article code on the website containing the list of registers. Products with earlier firmware versions may not be compatible with this list.

Optional settings

To assure correct communication, the NBT needs to be activated in only two devices on the Modbus RTU network. If necessary, enable the NBT resistor via 3SModbus or Sensistant (Holding register 9).

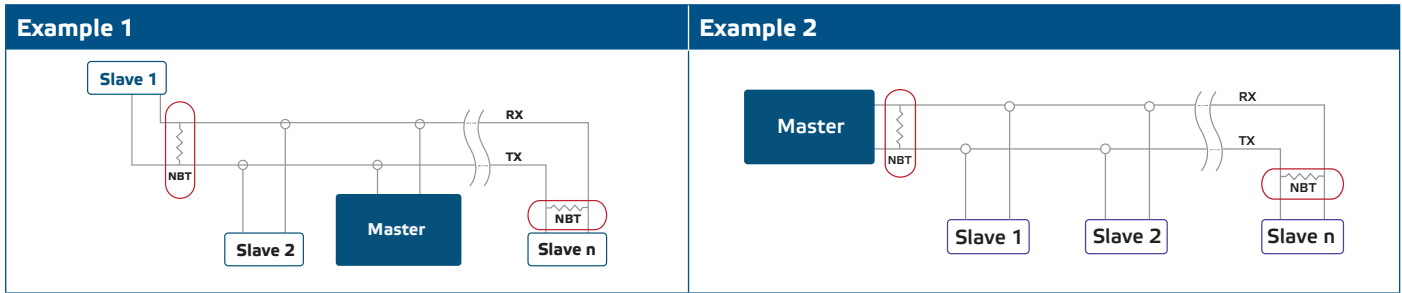

NOTE

On a Modbus RTU network, two bus terminators (NBTs) need to be activated.

OPERATING INSTRUCTIONS

Calibration procedure

All sensor elements are calibrated and tested in our factory. Recalibration is not necessary.

Firmware update

New functionalities and bug fixes are made available via a firmware update. In case your device does not have the latest firmware installed, it can be updated. SenteraWeb is the easiest way to update the firmware of the unit. In case you do not have an internet gateway available, the firmware can be updated via the 3SM boot application (part of the Sentera 3SMcenter software suite).

NOTE

Make sure the power supply does not get interrupted during "bootload" procedure.

VERIFICATION OF INSTALLATION INSTRUCTIONS

If your device does not function as expected, please check the connections.

TRANSPORT AND STORAGE

Avoid shocks and extreme conditions; stock in original packing.

WARRANTY AND RESTRICTIONS

Two years from the delivery date against defects in manufacturing. Any modifications or alterations to the product after the date of publication relieve the manufacturer of any responsibilities. The manufacturer bears no responsibility for any misprints or mistakes in this data.

MAINTENANCE

In normal conditions this product enclosure is maintenance-free. If soiled, clean with a dry or damp cloth. In case of heavy pollution, clean with a non-aggressive product. The sensor element protector is made from porous material and, when exposed to extreme climate conditions such as dust, water and wind, may become clogged. This may result in faulty measurements. Please clean with mild non-acidic detergent. In these circumstances the unit should be disconnected from the supply. Pay attention that no fluids enter the unit. Only reconnect it to the supply when it is completely dry.