

GTEE1 | ELECTRONIC TEMPERATURE CONTROLLER

Mounting and operating instructions



Table of contents

SAFETY AND PRECAUTIONS	3
PRODUCT DESCRIPTION	4
ARTICLE CODES	4
INTENDED AREA OF USE	4
TECHNICAL DATA	4
STANDARDS	5
WIRING AND CONNECTIONS	5
OPERATIONAL DIAGRAM	5
MOUNTING INSTRUCTIONS IN STEPS	6
VERIFICATION OF INSTALLATION INSTRUCTIONS	9
MODBUS REGISTERS MAPS	10
TRANSPORT AND STORAGE	11
WARRANTY AND RESTRICTIONS	11
MAINTENANCE	11

SAFETY AND PRECAUTIONS



Read all the information, the datasheet, mounting and operating instructions and study the wiring and connection diagram before working with the product. For personal and equipment safety, and for optimum product performance, make sure you entirely understand the contents before installing, using, or maintaining this product.



For safety and licensing (CE) reasons, unauthorised conversion and /or modifications of the product are inadmissible.



The product should not be exposed to abnormal conditions, such as: extreme temperatures, direct sunlight or vibrations. Long-term exposure to chemical vapours in high concentration can affect the product performance. Make sure the work environment is as dry as possible; avoid condensation.



All installations shall comply with local health and safety regulations and local electrical standards and approved codes. This product can only be installed by an engineer or a technician who has expert knowledge of the product and safety precautions.



Avoid contacts with energised electrical parts; always treat the product as if it is live. Always disconnect the power supply before connecting, servicing or repairing the product.



Always verify that you apply appropriate power supply to the product and use appropriate wire size and characteristics. Make sure that all the screws and nuts are well tightened and fuses (if any) are fitted well.



Recycling of equipment and packaging should be taken into consideration and these should be disposed of in accordance with local and national legislation / regulations.



In case there are any questions that are not answered, please contact your technical support or consult a professional.

PRODUCT DESCRIPTION

The GTEE1 fan speed controller automatically regulates the speed of single phase voltage controllable motors (230 VAC / 50–60 Hz) according to the measured temperature values and controls a heater according to a temperature setpoint. The fan speed will increase as the measured temperature exceeds the setpoint temperature.

ARTICLE CODES

Article code	I _{max}
GTEE1-30-DT	3 A
GTEE1-60-DT	6 A

INTENDED AREA OF USE

- Ventilation control by single phase 230 VAC units in function of the measured temperature. Application field: greenhouses, stables, sheds, etc.
- Temperature controlled ventilation systems
- For indoor use only

TECHNICAL DATA

- Supply voltage: 230 VAC ±10 % / 50–60 Hz
- Output load:
 - ▶ GTEE1-30-DT: 3 A
 - ▶ GTEE1-60-DT: 6 A
- V_{min} adjustable via potentiometer: 80–160 VAC
- V_{max} adjustable via potentiometer: 180–230 VAC
- Proportional range: 2 °C
- Temperature range: 21–35 °C
- Plug and play, no wiring needed
- 3 Schuko Euro sockets for connecting a supply fan, an extraction fan and a heater
- Integrated 4 m flying lead PT500 temperature probe
- All sockets are separately and externally fused
- Integrated external plate for easy wall fixing
- Potentiometer for temperature setpoint range: 21–35 °C
- Enclosure: plastic R-ABS, V; grey colour (RAL 7035)
- Protection standard: IP54 (according to EN 60529)
- Operating ambient conditions:
 - ▶ temperature: 0–40 °C
 - ▶ rel. humidity: <95 % rH (non-condensing)
- Storage temperature: -40–50 °C

STANDARDS

- Low Voltage Directive 2014/35/EC: EN 60335-1:2012
- EMC Directive 2014/30/EC: EN 61000-6-3:2007/A1:2011/AC:2012, EN 61000-6-2:2005/AC:2005
- WEEE Directive 2012/19/EC
- RoHS Directive 2011/65/EC

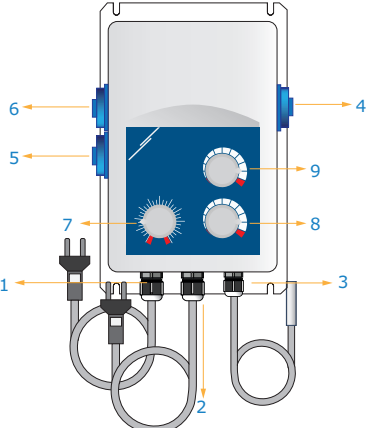

WIRING AND CONNECTIONS

	1 - Standard power supply cable with Euro plug (length 1,5 m)	Power supply	230 VAC / 50–60 Hz
	2 - Standard power supply Euro plug cable for controller (1,5 m)	Power supply	230 VAC / 50-60 Hz
	3 - Temperature sensor probe	Length	4 m, connected to PT500
		Resistance	500 Ω at 0 °C
		Sensor measuring range	-30–70 °C
	4 - AC extraction fan socket	Load connection	230 VAC / 50–60 Hz, I _{max} 16 A (3,6 kW)
	5 - AC supply fan socket		
	6 - Heater socket		
	7 - Temperature setpoint potentiometer		21–35 °C, 1 °C scale
8 - V _{min} speed potentiometer		80–160 VAC	
9 - V _{max} speed potentiometer		180–230 VAC	

OPERATIONAL DIAGRAM

Operational diagrams

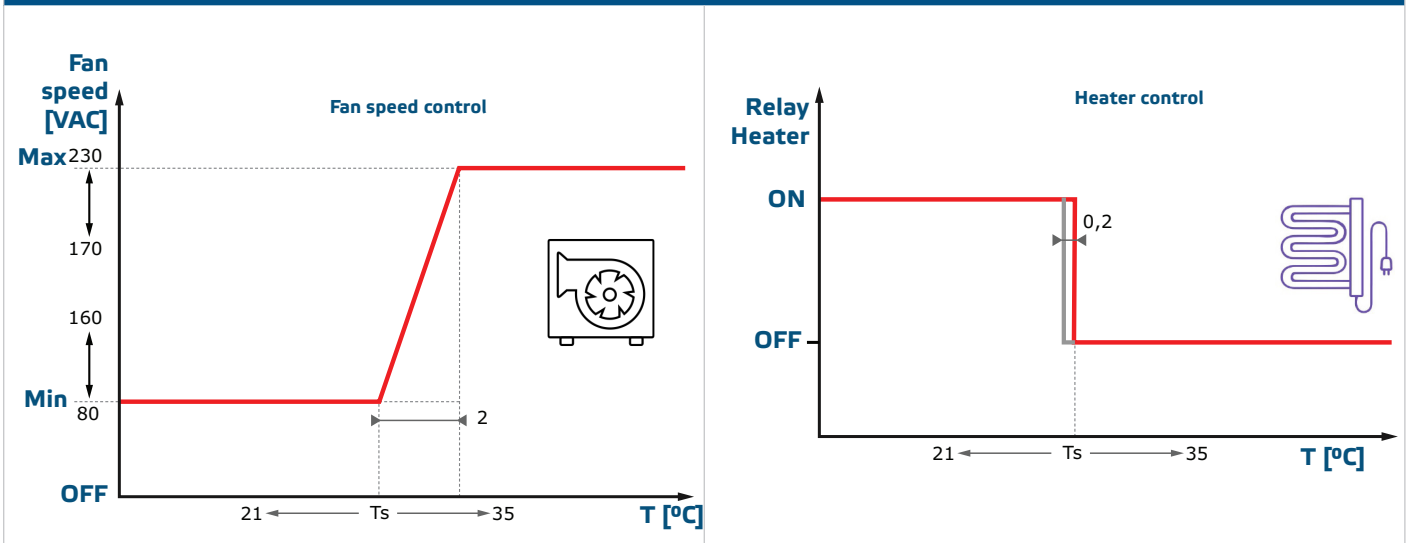

MOUNTING INSTRUCTIONS IN STEPS

Before you start mounting the GTEE1, read carefully “**Safety and Precautions**” and follow these steps. Choose a smooth solid surface for installation (a wall, panel, etc.).

Follow these steps:

1. Drill holes into the surface and secure the fastenings (hooks, wall plugs, etc.) into them. Mind the correct mounting position and unit mounting dimensions (see **Fig. 1 Mounting dimensions** and **Fig. 2 Mounting position**).
2. Pay attention to the following instructions in order to minimize the operating temperature:
 - 1.1 Respect the distances both between the wall / ceiling and the device and between two devices as shown in **Fig. 2**. In order to ensure sufficient ventilation of the controller, clearance on every side has to be maintained.
 - 1.2 When installing the device, please keep in mind that the higher you install it, the warmer the device will get. For example, in a technical room the correct installation height can be of great importance.
 - 1.3 If maximum ambient temperature cannot be adhered to, please provide extra forced ventilation / cooling.
 - 1.4 Leave sufficient space around the unit (for load connecting to the sockets). Allow at least 90–100 mm for connection maintenance (to insert plug/plugs into the sockets).

Not respecting the abovelisted rules can reduce service life and relieves the manufacturer of any responsibilities.



ATTENTION

Do not install the controller above heating equipment.

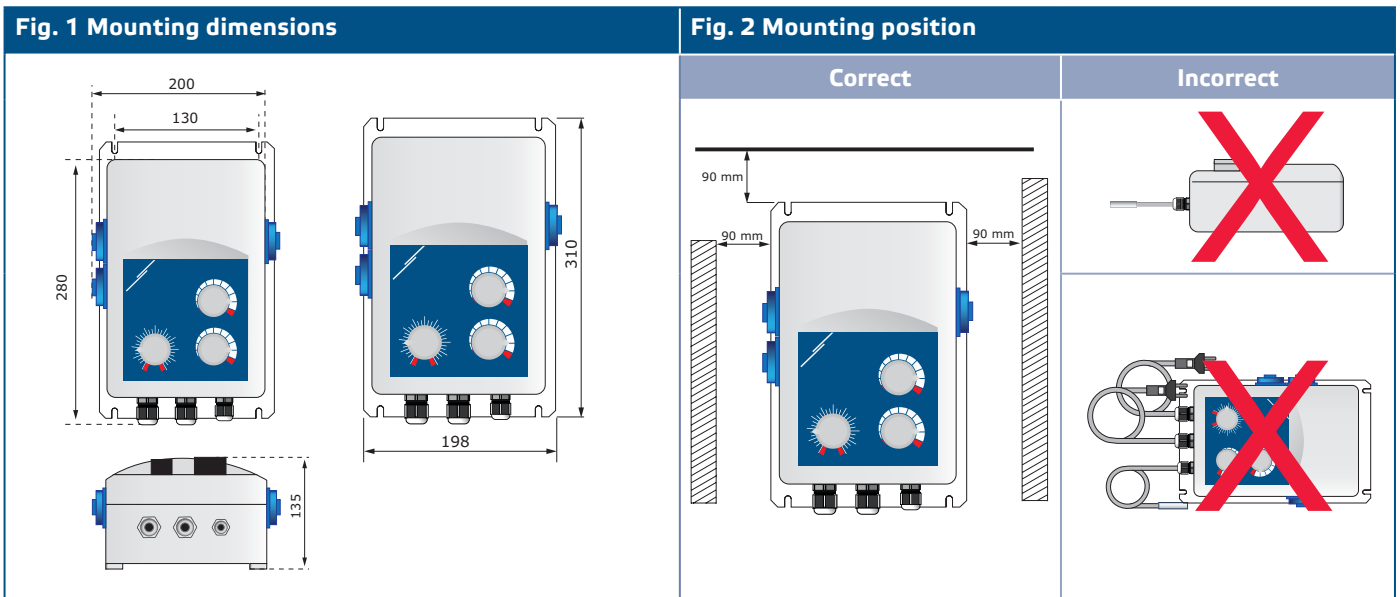

3. Fix the unit onto the wall /panel.

ATTENTION

A safety isolator / disconnect switch should be installed on the mains electricity side of all motor drives.

NOTE

The Schuko sockets are intended only for connecting a supply fan, an extraction fan and a heater as indicated on the device. Do not plug other types of electric appliances into them!

OPERATING INSTRUCTIONS

ATTENTION

Make sure the mains supply voltage is within the admissible rated maximum current of the product.

1. Switch off the mains power supply before connecting any power cables.
2. Plug load (fans and heater) cables into the sockets.
3. Install the PT500 temperature probe in an appropriate zone in order to measure the relevant ambient temperature.
4. Plug the GTEE1 into the mains electricity network.
5. Select the minimum and maximum operating speed by turning the relevant potentiometers to the relevant position (**Fig. 3**).
6. Select the desired temperature setpoint by turning the TEMP. potentiometer (**Fig. 3**).

Fig. 3 Knob positions

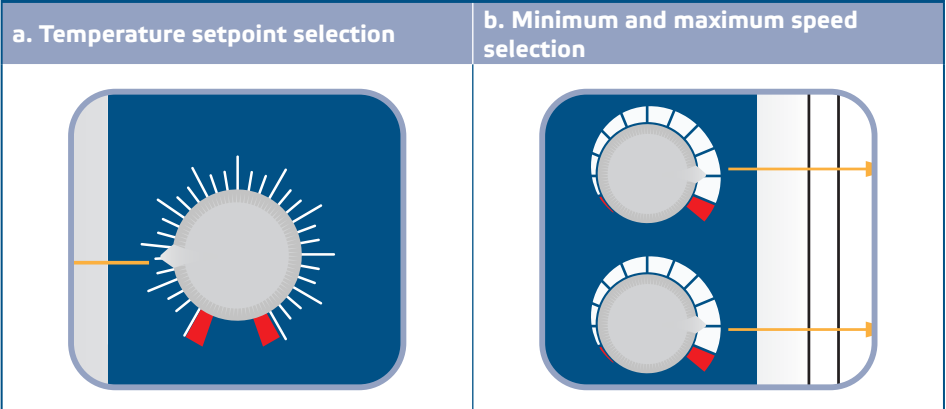

ATTENTION

External fuses need to be installed for protection:

- For the heater: 16 A or according the heater power
- For the controller: GTEE1-30-DT – 5 A / GTEE1-60-DT – 8 A

VERIFICATION OF INSTALLATION

ATTENTION

Use only tools and equipment with non-conducting handles when working on electrical devices.

Perform the following to test the operation of the your controller:

1. Plug in the supply cable.
2. Set the MIN. SPEED and MAX. SPEED potentiometers to desired position.
3. Position the TEMP. potentiometer to max. position (35 °C).
4. The connected fans will run at min. speed while the heater will be on.
5. Adjust the TEMP. potentiometer to temperature equal to the ambient temperature (about 21 °C).
6. The connected fans will run at maximum selected speed if the difference between the setpoint temperature and the ambient temperature is higher than the value of proportional range, i. e. 2 °C (hold the temperature probe in your hand to check). The heater will be off.
7. If the device does not function as expected, check the connections.

Safe operation depends on proper installation. Before start up, ensure the following:

- The mains supply is connected correctly.
- Protection is provided against electrical shock.
- The cables are the appropriate size and fuse-protected.
- There is sufficient air flow around the unit.

ATTENTION

The unit is supplied with electrical energy at voltages high enough to inflict personal injury or threat to health. Take the relevant safety measures.

ATTENTION

Disconnect and confirm that there is no live current flowing to the unit before servicing.

ATTENTION

Avoid exposing the controller to direct sunlight!

TRANSPORT AND STORAGE

Avoid shocks and extreme conditions; stock in the original packing.

WARRANTY AND RESTRICTIONS

Two years from the delivery date against defects in manufacturing. Any modifications or alterations to the product after the date of publication relieve the manufacturer of any responsibilities. The manufacturer bears no responsibility for any misprints or mistakes in this data.



ATTENTION

Use only fuses of the type and rating specified above; otherwise, loss of warranty will ensue.

MAINTENANCE

In normal conditions this product is maintenance-free. If soiled, clean with a dry or damp cloth. In case of heavy pollution, clean with a non-aggressive product. In these circumstances the unit should be disconnected from the supply. Pay attention that no fluids enter the unit. Only reconnect it to the supply when it is completely dry.