

# GTEX1-60 | ELECTRONIC FAN SPEED CONTROLLER

## Mounting and operating instructions

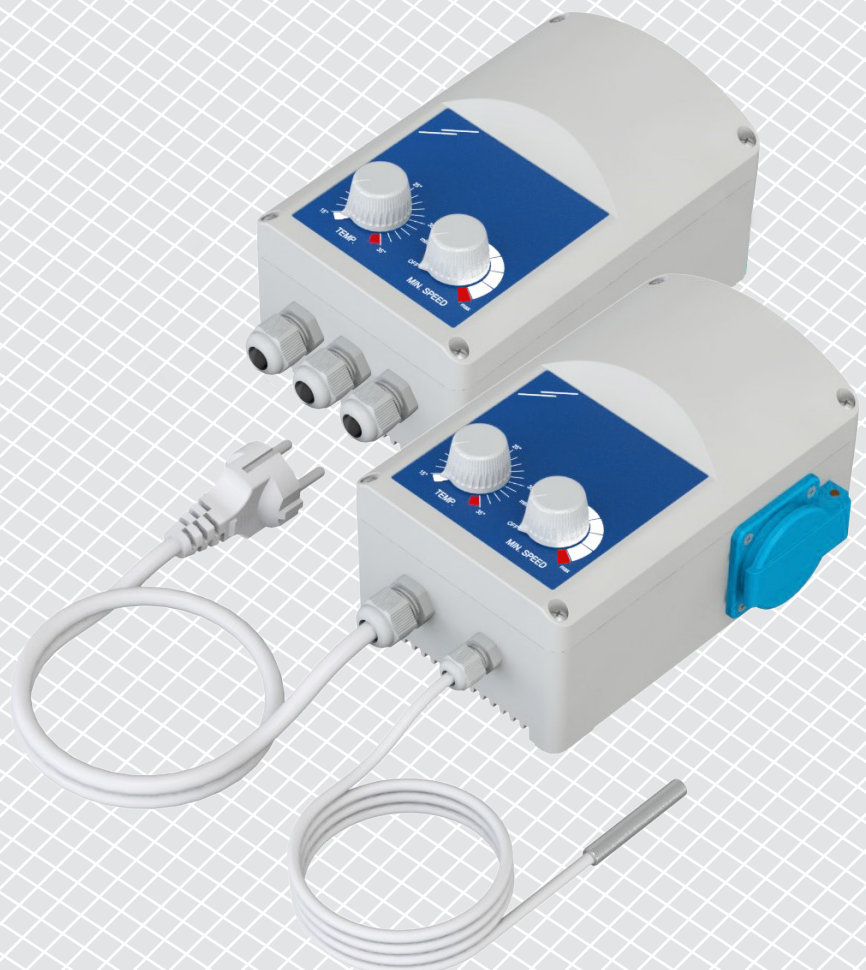

# Table of contents

<b>SAFETY AND PRECAUTIONS</b>	<b>3</b>
<b>PRODUCT DESCRIPTION</b>	<b>4</b>
<b>ARTICLE CODES</b>	<b>4</b>
<b>INTENDED AREA OF USE</b>	<b>4</b>
<b>TECHNICAL DATA</b>	<b>4</b>
<b>STANDARDS</b>	<b>5</b>
<b>WIRING AND CONNECTIONS</b>	<b>5</b>
<b>OPERATIONAL DIAGRAM</b>	<b>5</b>
<b>MOUNTING INSTRUCTIONS IN STEPS</b>	<b>6</b>
<b>VERIFICATION OF INSTALLATION</b>	<b>8</b>
<b>TROUBLESHOOTING</b>	<b>9</b>
<b>TRANSPORT AND STORAGE</b>	<b>9</b>
<b>WARRANTY AND RESTRICTIONS</b>	<b>9</b>
<b>MAINTENANCE</b>	<b>9</b>

## SAFETY AND PRECAUTIONS

---



Read all the information in this manual, in the datasheet and in the Modbus Register Map before working with the product. For personal and equipment safety and for optimum product performance, make sure you fully understand the content before installing, using or servicing this product.



For safety and licensing (CE) reasons, unauthorised conversions and / or modifications of the product are inadmissible.



The product should not be exposed to abnormal conditions, such as extreme temperatures, direct sunlight or vibrations. Long-term exposure to chemical vapours in high concentration can affect the product performance. Make sure the work environment is as dry as possible and avoid condensation.



All installations must comply with local health and safety regulations and local electrical standards and approved codes. This product should only be installed by an engineer or a technician with expert knowledge of the product and safety precautions.



Avoid contact with energised electrical parts. Always disconnect the power supply before connecting, servicing or repairing the product.



Always check that you are connecting the correct power supply to the product and use wires of the correct characteristics and cross-section. Make sure all screws and nuts are properly tightened and fuses (if any) are in place.



Consideration should be given to recycling the equipment and packaging. These should be disposed of in accordance with local and national laws and regulations.



If there are questions that are not answered, contact your technical support or consult a professional.

## PRODUCT DESCRIPTION

The GTE fan speed controller automatically regulates the speed of single-phase voltage-controllable motors (230 VAC / 50–60 Hz) based on the measured temperature values. The maximum speed can be adjusted via an internal trimmer. The minimum speed and temperature setpoint can be adjusted via external potentiometers. There are two product versions: -DM with Modbus RTU communication and -DT with an integrated motor socket, power cable and a PT500 temperature probe. The fan speed will increase as the measured temperature exceeds the setpoint temperature.

## ARTICLE CODES

Code	Temperature range	PT500 temperature sensor included	Schuko socket for simple motor connection	Integrated power supply cable	Modbus RTU
GTE21-60-DM	5–35 °C	no	no	no	yes
GTE21-60-DT	5–35 °C	yes	yes	yes	no
GTE-1-60-DM	15–35 °C	no	no	no	yes
GTE-1-60-DT	15–35 °C	yes	yes	yes	no

## INTENDED AREA OF USE

- Greenhouses and temperature-controlled ventilation systems
- For indoor use only

## TECHNICAL DATA

- Supply voltage: 230 VAC ±10 % / 50–60 Hz
- Output load: max. 6 A
- Potentiometer for minimum speed setting
- Internal trimmer for maximum speed setting
- Adjustable hysteresis and proportional range
- Potentiometer for temperature setpoint range: 5–35 °C or 15–35 °C, depending on the product version
- PT500 temperature probe input (pre-wired for the -DT version and separately available for the -DM version)
- Modbus RTU communication (only in -DM version)
- Schuko socket for motor connection (only in -DT version)
- Euro plug for power supply (only in -DT version)
- Pre-wired temperature sensor and supply cable (only in -DT version)
- Enclosure: plastic R-ABS, V; grey colour (RAL 7035)
- Protection standard: IP54 (according to EN 60529)
- Storage temperature: -40–50 °C
- Operating ambient conditions:
  - ▶ temperature: 0–40 °C
  - ▶ rel. humidity: <95 % rH (non-condensing)
- Storage temperature: -40–50 °C

## STANDARDS

- Low Voltage Directive 2014/35/EU
- EMC Directive 2014/30/EU: EN 61000-3-2:2014, EN 61000-6-2:2005/AC:2005 and EN 61000-6-3:2007/A1:2011/AC:2012
- Commission Delegated Directive (EU) 2015/863 of 31 March 2015 amending Annex II to Directive 2011/65/EU of the European Parliament and of the Council as regards the list of restricted substances



## WIRING AND CONNECTIONS

GTEX1-60-DM	
L	Supply voltage 230 VAC / 50–60 Hz – mono phase ±10 %
N	Neutral
L1	230 VAC unregulated output (max. 2 A)
GND, T (TEMP)	PT500 temperature sensor
A	RS485 signal A
/B	RS485 signal /B
P5	Motor connection
GTEX1-60-DT	
L	Supply voltage 230 VAC / 50–60 Hz – mono phase ±10 %
N	Neutral
PE	Ground
L1	230 VAC unregulated output (max. 2 A)
GND, T (TEMP)	PT500 temperature sensor
Schuko socket	Motor connection

## OPERATIONAL DIAGRAM

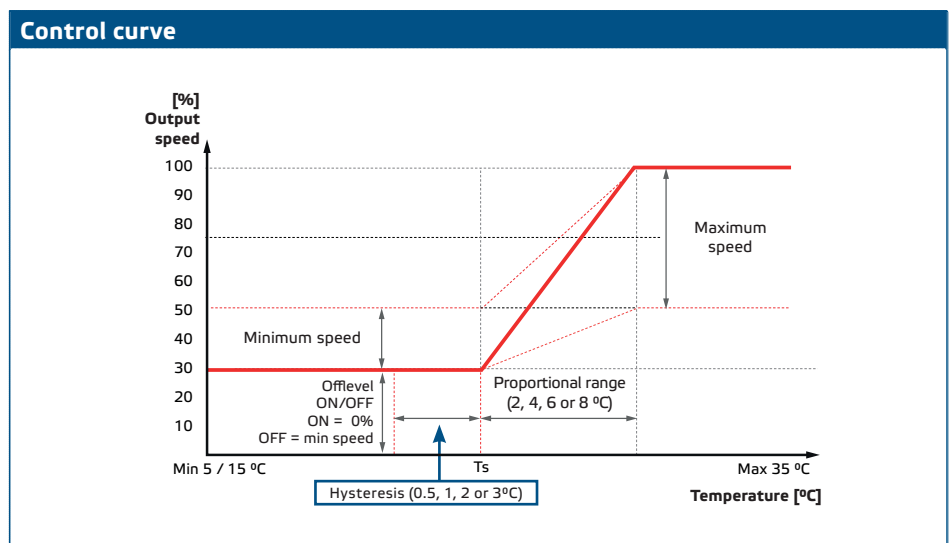

## MOUNTING INSTRUCTIONS IN STEPS

Before you start mounting the unit, read carefully **“Safety and Precautions”**. Choose a flat surface for installation (e.g. a wall, panel, etc.) and follow these steps:

**-DM version — Mounting steps:** [Go to -DT version ▶](#)

1. Make sure that the mains supply is switched off.
2. Unscrew the front cover and open the enclosure. Mind the wires that connect the potentiometer with the printed circuit board. Insert the supply and sensor cables through the cable glands.
3. Fix the unit to the wall or panel using the provided screws and dowels. Mind the correct mounting position and unit mounting dimensions. (See **Fig. 1 Mounting dimensions** and **Fig. 2 Mounting position**.)

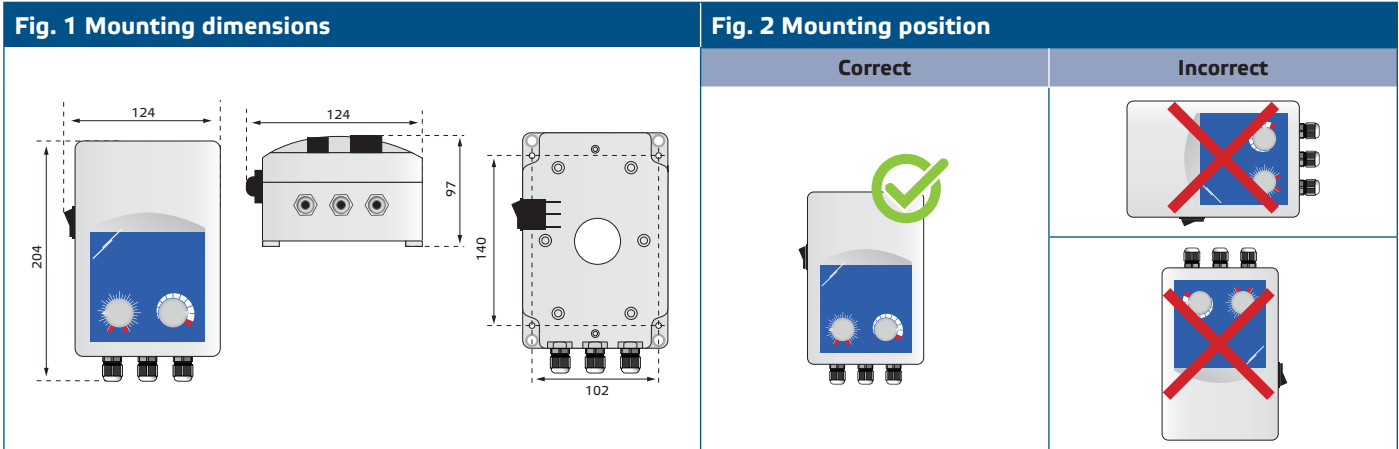

4. Do the wiring according to the information in section **“Wiring and connections”** while adhering to **Fig. 3** below.

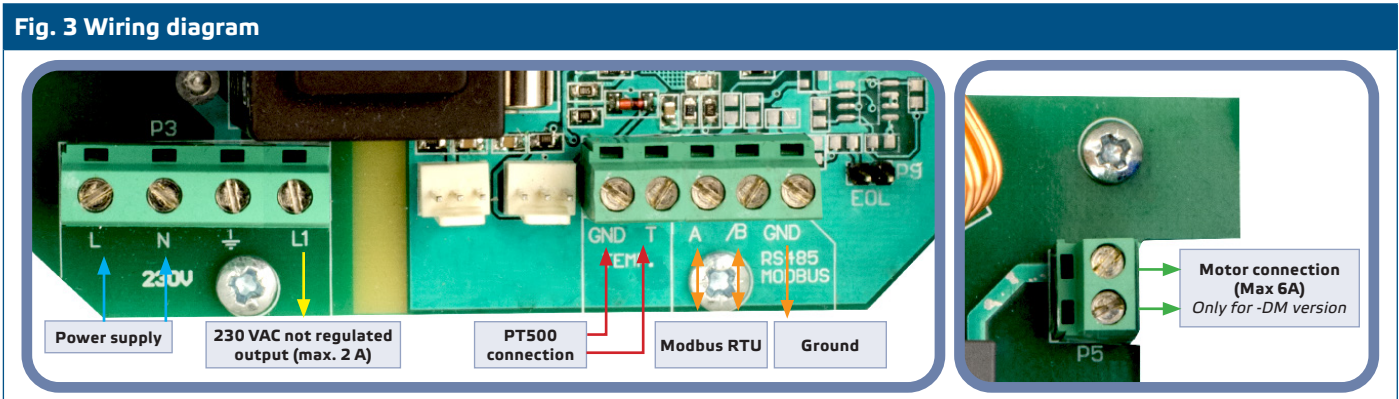

5. Fix the jumpers accordingly - see **Fig. 4 Jumper positions** below.

### NOTE

The -DM version can be used both as a stand-alone unit or in conjunction with a computer and it can be operated by Sentera’s 3SModbus software or the Sensistant configurator. When the -DM version is used as a stand-alone unit, its jumpers need to be set to the desired values. When it is used in Modbus mode, its parameters are set via Modbus RTU, so the jumpers can remain in their factory set positions. Refer to the **Modbus Holding Registers Table** for the relevant settings.

**Fig. 4 Jumper positions**

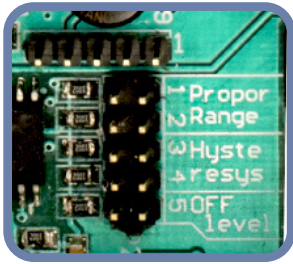

Propor. Range (JP1 & JP2)		Hysteresis (JP3 & JP4)		Off-level (JP5 & JP6)	
1	2	3	4	5	On
1	2	3	4	5	Off (factory preset)
1	2	3	4		
1	2	3	4		

6. Set the maximum speed trimmer to the desired value. You can choose from the range 170–230 VAC. The factory setting is 230 VAC.

**7. Optional setting:**

- The Network Bus Terminator (NBT) (see **Fig. 5 NBT jumper**) used with Modbus RTU. By default the NBT is disconnected.

**Fig. 5 NBT jumper**

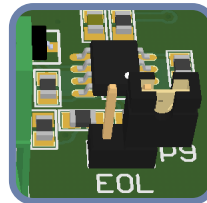

	NBT is connected
	NBT is disconnected (factory pre-set)

**NOTE**

*Connect the NBT only in the two most distant units on the network line.*

- Connect the NBT by placing the jumper onto the pins as indicated above only if your unit starts or terminates the network. Skip this step if your unit is not the first or last on the network. See the examples below for more information.

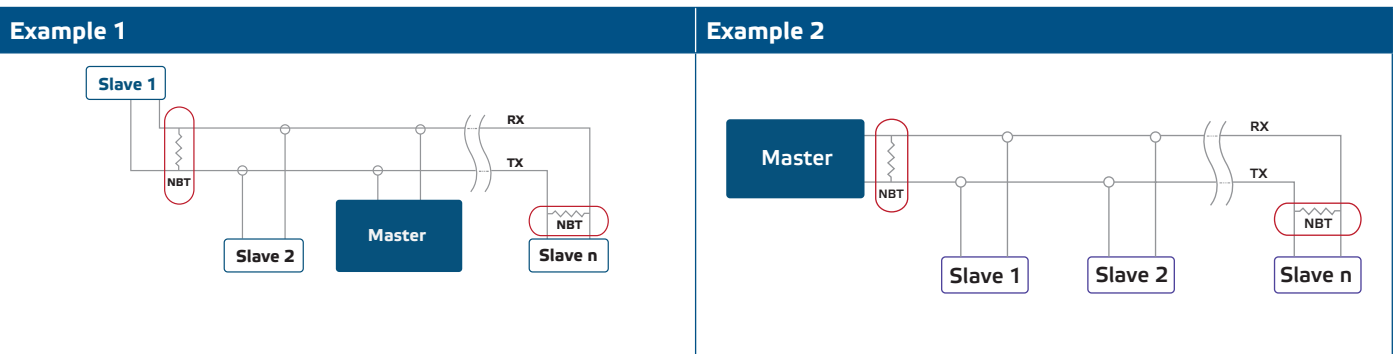

- Put back the front cover and fix it.
- Turn on the mains supply.

**-DT version — Mounting steps:** [Back to -DM version ►](#)

1. Make sure the GTE controller is not connected to the mains supply.
2. Unscrew the front cover and open the enclosure. Mind the wires that connect the potentiometer with the printed circuit board.

## NOTE

For the -DT version, the power supply and the temperature sensor (PT500) are included in the set and are factory connected. Also, the -DT version has a Schuko socket to plug in the motor / fan.

- Fix the unit to the wall or panel using the provided screws and dowels. Mind the correct mounting position and unit mounting dimensions. (See **Fig. 6 Mounting dimensions** and **Fig. 7 Mounting position**.)

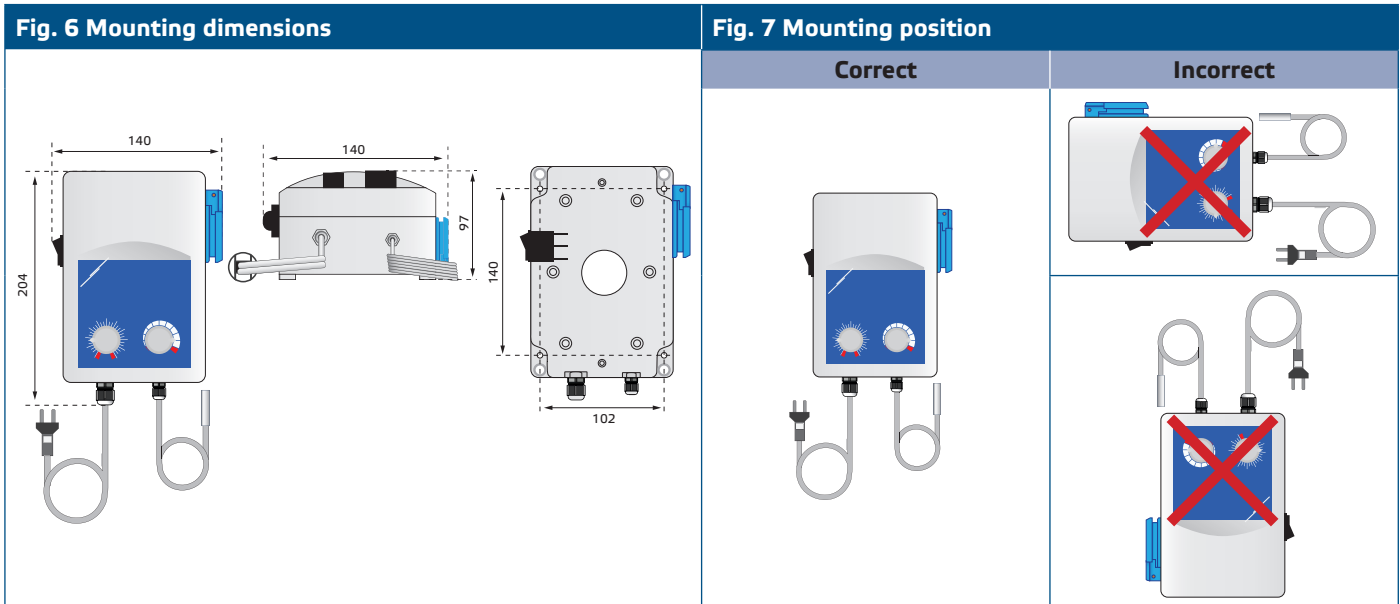

- Fix the jumpers accordingly - see **Fig. 4 Jumper positions**.
- Set the maximum speed trimmer to the desired value (see **Fig. 8 Max. speed trimmer**). You can choose from the range 170–230 VAC. The factory setting is 230 VAC.

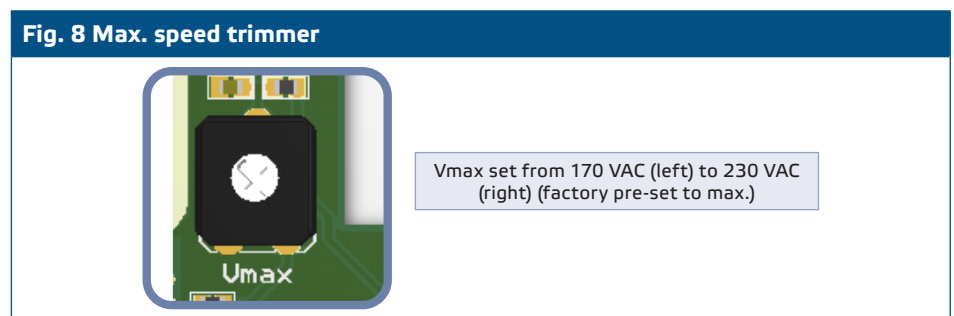

- Put back the front cover and fix it.
- Plug the motor / fan cable into the Schuko socket.
- Plug the power cable of the GTE controller into the mains supply.

## VERIFICATION OF INSTALLATION

## ATTENTION

Use only tools and equipment with non-conducting handles when working on electrical devices.



1. Make sure that the controller is connected to the mains supply.
2. Switch on the controller via the illuminated ON/OFF switch.
3. Position the TEMP. potentiometer to its max. position (35 °C). (See **Fig. 9 -DM version** and **Fig. 10 -DT version**)

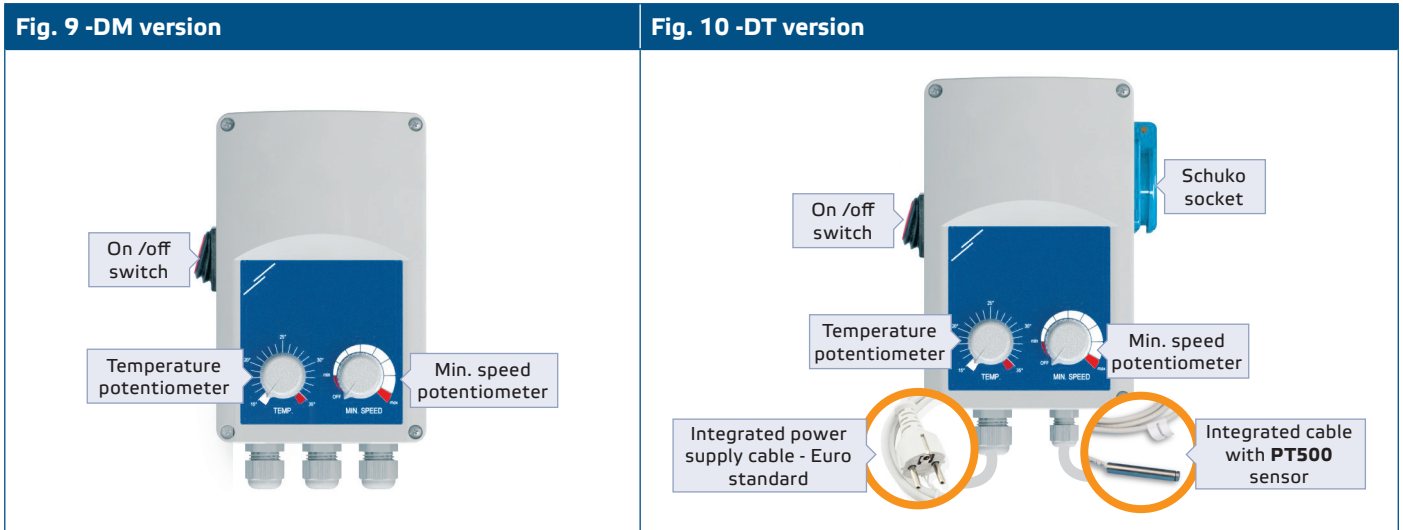

4. The connected motor will run at min. speed.
5. Adjust the TEMP. potentiometer to temperature equal to the ambient temperature.
6. The motor / fan will run at min. speed and will speed up if the ambient temperature rises (hold the temperature probe in your hands to check).
7. Adjust the temperature potentiometer to the min. position (5 °C for GTE21-60-DM and GTE21-60-DT or 15 °C for GTE-1-60-DM and GTE-1-60-DT)
8. The motor will run at max. selected speed if the difference between the setpoint temperature and the ambient temperature is more than the value of the selected proportional range.
9. If the unit does not operate as explained above, check the connections and settings.

## TROUBLESHOOTING

In case of faulty operation, please check if:

- the right voltage is applied;
- all of the connections are correct;
- the device is functioning.

## TRANSPORT AND STORAGE

Avoid shocks and extreme conditions; stock in the original packing.

## WARRANTY AND RESTRICTIONS

Two years from the delivery date against defects in manufacturing. Any modifications or alterations to the product after the date of publication relieve the manufacturer of any responsibilities. The manufacturer bears no responsibility for any misprints or mistakes in this data.



**ATTENTION**

*Use only fuses of the type and rating specified above; otherwise, loss of warranty will ensue.*

## MAINTENANCE

---

In normal conditions this product is maintenance-free. If soiled, clean with a dry or damp cloth. In case of heavy pollution, clean with a non-aggressive product. In these circumstances, the unit should be disconnected from the supply. Pay attention that no fluids enter the unit. Only reconnect it to the supply when it is completely dry.