

DTS-L | DIGITAL DUCT TEMPERATURE SENSOR

Mounting and operating instructions

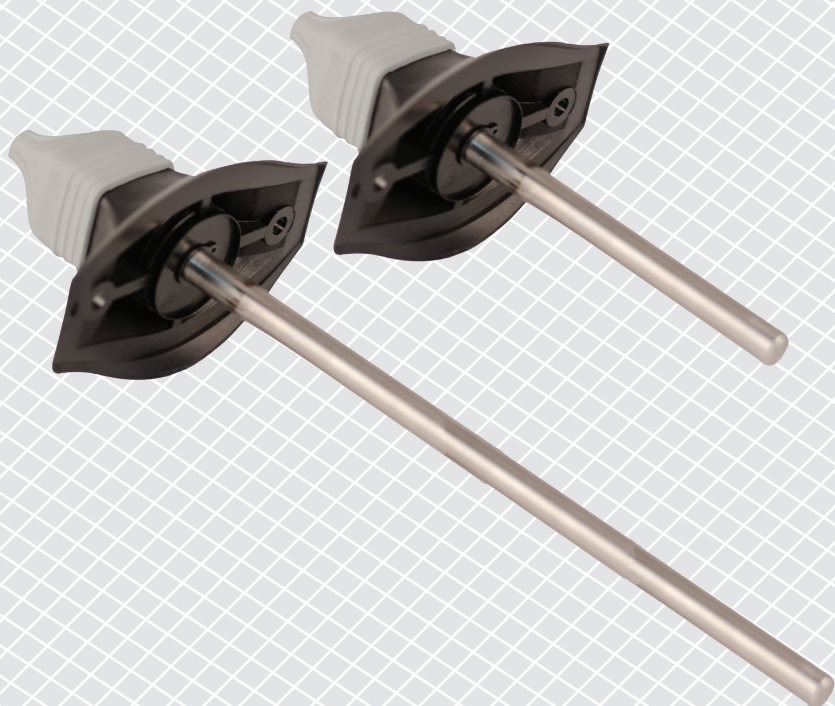

Table of contents

SAFETY AND PRECAUTIONS	3
PRODUCT DESCRIPTION	4
ARTICLE CODES	4
INTENDED AREA OF USE	4
TECHNICAL DATA	4
STANDARDS	4
WIRING AND CONNECTIONS	5
MOUNTING & OPERATING INSTRUCTIONS IN STEPS	5
VERIFICATION OF INSTALLATION INSTRUCTIONS	7
TRANSPORT AND STORAGE	7
WARRANTY AND RESTRICTIONS	7
MAINTENANCE	7

SAFETY AND PRECAUTIONS



Read all the information, the datasheet, Modbus map, mounting and operating instructions and study the wiring and connection diagram before working with the product. For personal and equipment safety, and for optimum product performance, make sure you entirely understand the contents before installing, using, or maintaining this product.



For safety and licensing (CE) reasons, unauthorised conversion and /or modifications of the product are inadmissible.



The product should not be exposed to abnormal conditions, such as extreme temperatures, direct sunlight or vibrations. Long-term exposure to chemical vapours in high concentration can affect the product performance. Make sure the work environment is as dry as possible; avoid condensation.



All installations shall comply with local health and safety regulations and local electrical standards and approved codes. This product can only be installed by an engineer or a technician who has expert knowledge of the product and safety precautions.



Avoid contacts with energised electrical parts. Always disconnect the power supply before connecting, servicing or repairing the product.



Always verify that you apply appropriate power supply to the product and use appropriate wire size and characteristics. Make sure that all the screws and nuts are well tightened and fuses (if any) are fitted well.



Recycling of equipment and packaging should be taken into consideration and these should be disposed of in accordance with local and national legislation / regulations.



In case there are any questions that are not answered, please contact your technical support or consult a professional.

PRODUCT DESCRIPTION

The DTS-L series are digital temperature sensors powered over Modbus with 3,3 VDC via an RJ12 connector. They are intended for duct channels and are compatible with various temperature control systems. The sensor element is placed in a stainless steel tube of different length - 80 or 160 mm, which simplifies the cleaning of the duct system.

ARTICLE CODES

Code	Supply	Probe length
DTS-L-080	24 VDC, PoM	80 mm
DTS-L-160		160 mm

INTENDED AREA OF USE

Measuring temperature in duct channels

TECHNICAL DATA

- Sensor range: -30—70 °C
- Modbus RTU communication
- Easy wiring via an RJ12 socket
- Supply voltage: 3,3 VDC, Power over Modbus
- Maximum power consumption: 0,026 W
- Nominal power consumption in normal operation: 0,025 W
- I_{max}: 8 mA
- Protection standard: IP65
- Operating ambient conditions:
 - ▶ temperature: -30—70 °C
 - ▶ rel. humidity: 5—95 % rH (non-condensing)

STANDARDS

- EMC directive 2014/30/EU: 
 - ▶ EN 61326-1:2013 Electrical equipment for measurement, control and laboratory use - EMC requirements - Part 1: General requirements
 - ▶ EN 61326-2-3:2013 Electrical equipment for measurement, control and laboratory use - EMC requirements - Part 2-3: Particular requirements - Test configuration, operational conditions and performance criteria for transducers with integrated or remote signal conditioning
 - ▶ EN 61326-2-5:2013 Electrical equipment for measurement, control and laboratory use - EMC requirements - Part 2-5: Particular requirements - Test configurations, operational conditions and performance criteria for devices with field bus interfaces according to IEC 61784-1
- RoHs Directive 2011/65/EC

WIRING AND CONNECTIONS

RJ12 sockets	
Pin 1	
Pin 2	Supply voltage
Pin 3	Modbus RTU communication, signal A
Pin 4	Modbus RTU communication, signal /B
Pin 5	
Pin 6	Ground, supply voltage

MOUNTING & OPERATING INSTRUCTIONS IN STEPS

Before you start mounting the DTS-L, read carefully **“Safety and Precautions”**.

Follow these steps:

1. When preparing to mount the DTS-L, bear in mind that the unit itself must be installed by fixing the flexible flange onto the outer surface of the tube, while the probe is inserted inside the duct, see **Fig. 1** and **Fig. 2** below.

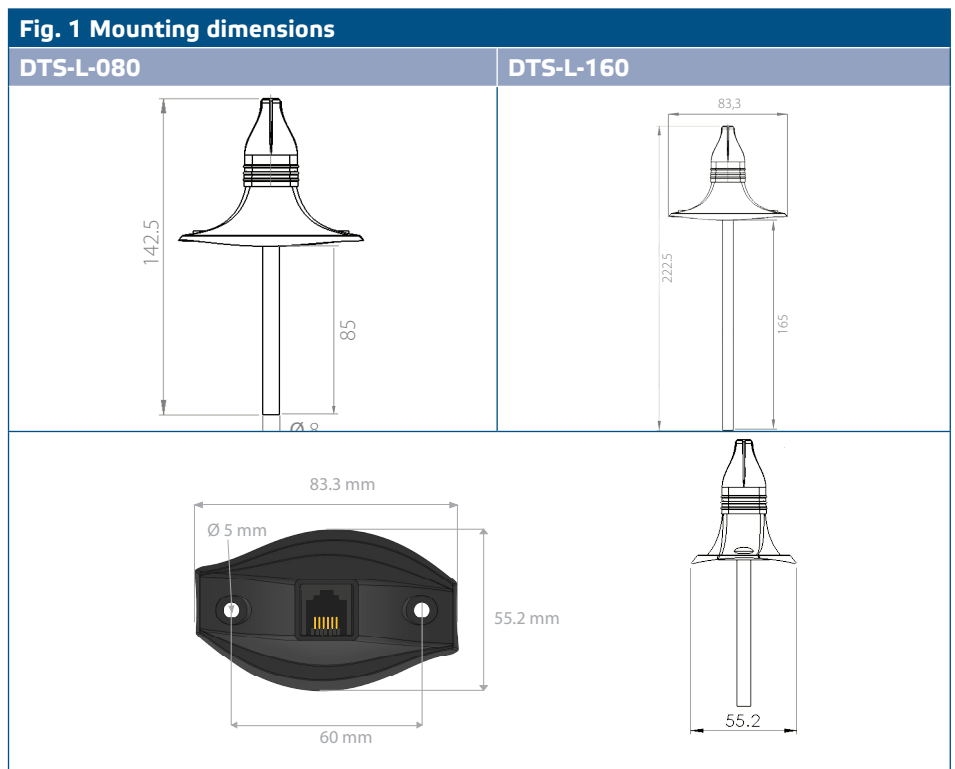
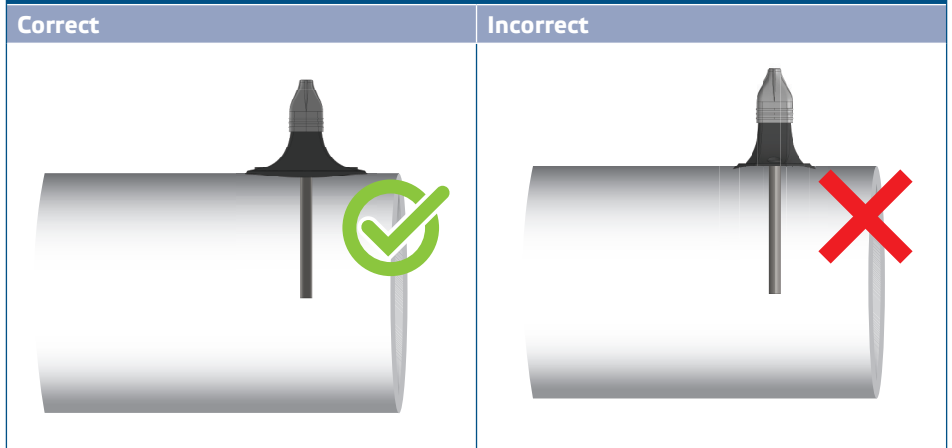

Fig. 2 Mounting position



2. Having selected the appropriate mounting location, proceed with the following steps:
 - 2.1 Drill an Ø 8,5 mm hole into the duct and insert the probe. Apply an air-tight sealing between probe and duct.
 - 2.2 Fix the flange onto the tube outer surface using appropriate screws.
3. Remove the rubber cap of the unit and insert the connecting cable into its opening (see Fig. 3).
4. Crimp the cable with an RJ12 connector adhering to the information in section "Wiring and connections" above and plug it into the socket (Fig. 3).

Fig. 3 Wiring and connections



5. Slide the cap along the cable to cover the connector and maintain the IP rating of the unit.
6. Customise the factory settings to the desired ones via the 3SModbus software or Sensistant (if necessary). For the default factory setting, see **Table Modbus register maps**.

Optional settings

To assure correct communication, the NBT needs to be activated in only two devices on the Modbus RTU network. If necessary, enable the NBT resistor via 3SModbus or Sensistant (*Holding register 9*).

Example 1

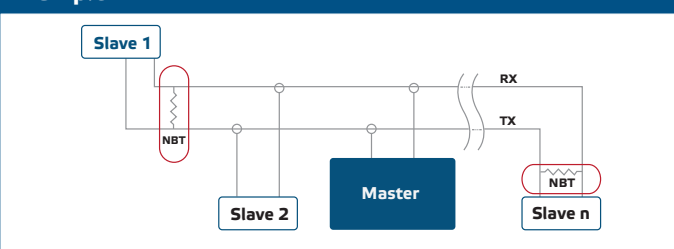

Example 2

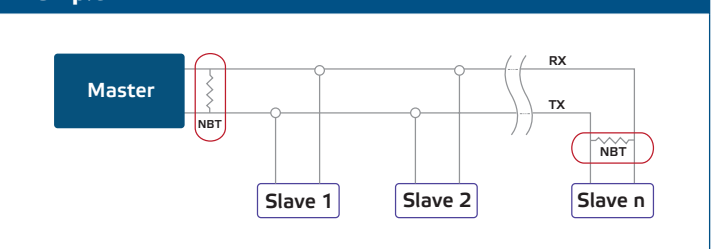



NOTE

On a Modbus RTU network, two bus terminators (NBTs) need to be activated.



CAUTION

Do not expose to direct sunlight!

VERIFICATION OF INSTALLATION INSTRUCTIONS

If your unit does not function as expected, please check the connections.

TRANSPORT AND STORAGE

Avoid shocks and extreme conditions; stock in original packing.

WARRANTY AND RESTRICTIONS

Two years from the delivery date against defects in manufacturing. Any modifications or alterations to the product after the date of publication relieve the manufacturer of any responsibilities. The manufacturer bears no responsibility for any misprints or mistakes in this data.

MAINTENANCE

In normal conditions this product is maintenance-free. If soiled, clean with a dry or damp cloth. In case of heavy pollution, clean with a non-aggressive product. In these circumstances the unit should be disconnected from the supply. Pay attention that no fluids enter the unit. Only reconnect it to the supply when it is completely dry.