

DPSPM-LP

DIFFERENTIAL PRESSURE
CONTROLLER WITH DISPLAY

Mounting and operating instructions



Table of contents

SAFETY AND PRECAUTIONS	3
PRODUCT DESCRIPTION	4
ARTICLE CODES	4
INTENDED AREA OF USE	4
TECHNICAL DATA	4
STANDARDS	4
OPERATIONAL DIAGRAM	5
WIRING AND CONNECTIONS	5
MOUNTING INSTRUCTIONS IN STEPS	5
OPERATING INSTRUCTIONS	8
TRANSPORT AND STORAGE	11
WARRANTY AND RESTRICTIONS	11
MAINTENANCE	11

SAFETY AND PRECAUTIONS



Read all the information, the datasheet, Modbus map, mounting and operating instructions and study the wiring and connection diagram before working with the product. For personal and equipment safety, and for optimum product performance, make sure you entirely understand the contents before installing, using, or maintaining this product.



For safety and licensing (CE) reasons, unauthorised conversion and /or modifications of the product are inadmissible.



The product should not be exposed to abnormal conditions, such as extreme temperatures, direct sunlight or vibrations. Long-term exposure to chemical vapours in high concentration can affect the product performance. Make sure the work environment is as dry as possible; avoid condensation.



All installations shall comply with local health and safety regulations and local electrical standards and approved codes. This product can only be installed by an engineer or a technician who has expert knowledge of the product and safety precautions.



Avoid contacts with energised electrical parts. Always disconnect the power supply before connecting, servicing or repairing the product.



Always verify that you apply appropriate power supply to the product and use appropriate wire size and characteristics. Make sure that all the screws and nuts are well tightened and fuses (if any) are fitted well.



Recycling of equipment and packaging should be taken into consideration and these should be disposed of in accordance with local and national legislation / regulations.



In case there are any questions that are not answered, please contact your technical support or consult a professional.

PRODUCT DESCRIPTION

The DPSPM-LP series are high resolution differential pressure controllers (-125—125 Pa). The integrated PI control with anti-windup function offers the possibility to directly control EC motors / fans. They are equipped with a fully digital state-of-the-art pressure transducer designed for a wide range of applications. Zero point calibration and Modbus registers reset can be executed via a tactile switch. All parameters are accessible via Modbus RTU (3SModbus software or Sensistant).

ARTICLE CODES

Codes	Power supply	Maximum power consumption	Nominal power consumption	I _{max}	Operating range
DPSPM-LP	24 VDC, PoM	1,56 W	1,40 W	65 mA	-125—125 Pa

INTENDED AREA OF USE

- Building and controlled ventilation
- Differential pressure, air volume or air velocity measurement and control in HVAC applications
- Differential pressure / air flow monitoring and control in clean rooms
- Clean air and non-aggressive, non-combustible gases

TECHNICAL DATA

- 4-digit 7-segment LED display for indicating differential pressure or air volume flow
- Built-in digital high resolution differential pressure sensor
- Minimum differential pressure range span: 5 Pa
- Minimum volume flow range span: 10 m³/h
- Minimum air velocity range span: 1 m/s
- Selectable response time: 0,1—10 s
- Implemented K-factor
- Selectable internal voltage source for PWM output: 3,3 or 12 VDC
- Differential pressure, air volume or air velocity readout via Modbus RTU
- Air velocity can be measured via Modbus RTU (by using an external PSET-PTX-200 Pitot tube connection set)
- Selectable minimum and maximum operating ranges
- Modbus registers reset function (to factory pre-set values)
- Four LEDs for transmitter status indication
- Modbus RTU communication
- Sensor calibration procedure via tactile switch
- Aluminium pressure connection nozzles
- Accuracy: ±2 % of the operating range
- Operating ambient conditions:
 - ▶ Temperature: -5—65 °C
 - ▶ Rel. humidity: < 95 % rH (non-condensing)
- Storage temperature: -20—70 °C

STANDARDS

- EMC Directive 2014/30/EC: CE
 - ▶ EN 61326-1:2013 Electrical equipment for measurement, control and laboratory use - EMC requirements - Part 1: General requirements
 - ▶ EN 61326-2-3:2013 Electrical equipment for measurement, control and laboratory use - EMC requirements - Part 2-3: Particular requirements - Test configuration, operational conditions and performance criteria for transducers with integrated or remote signal conditioning
- WEEE Directive 2012/19/EC
- RoHs Directive 2011/65/EC

OPERATIONAL DIAGRAM

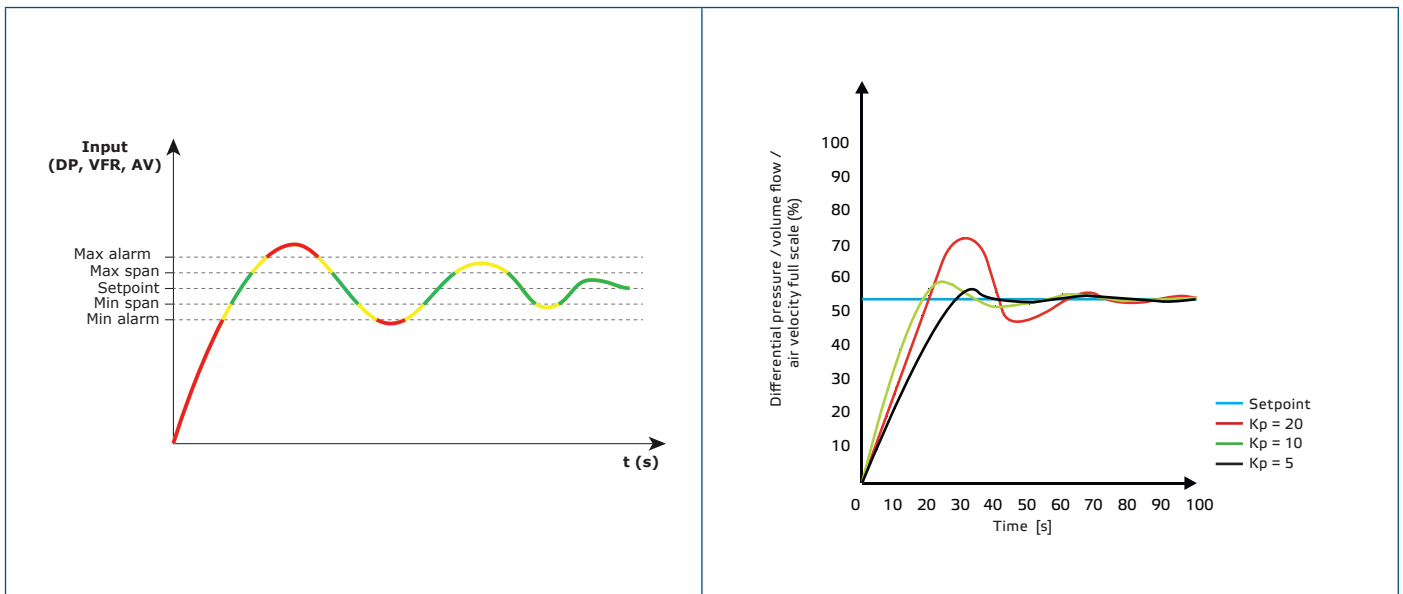

WIRING AND CONNECTIONS

RJ45 socket (Power over Modbus)		
Pin 1	24 VDC	Supply voltage
Pin 2		
Pin 3	A	Modbus RTU communication, signal A
Pin 4		
Pin 5	/B	Modbus RTU communication, signal /B
Pin 6		
Pin 7	GND	Ground, supply voltage
Pin 8		

MOUNTING INSTRUCTIONS IN STEPS

Before you start mounting the unit, read carefully **“Safety and Precautions”**. Choose a smooth surface for installation (a wall, panel, etc.) and follow these steps:

1. Unscrew the front cover of the enclosure to remove it.
2. Fix the enclosure onto the surface by means of suitable fasteners while adhering to the mounting dimensions shown in **Fig. 1** and the correct mounting position shown in **Fig. 2** below.

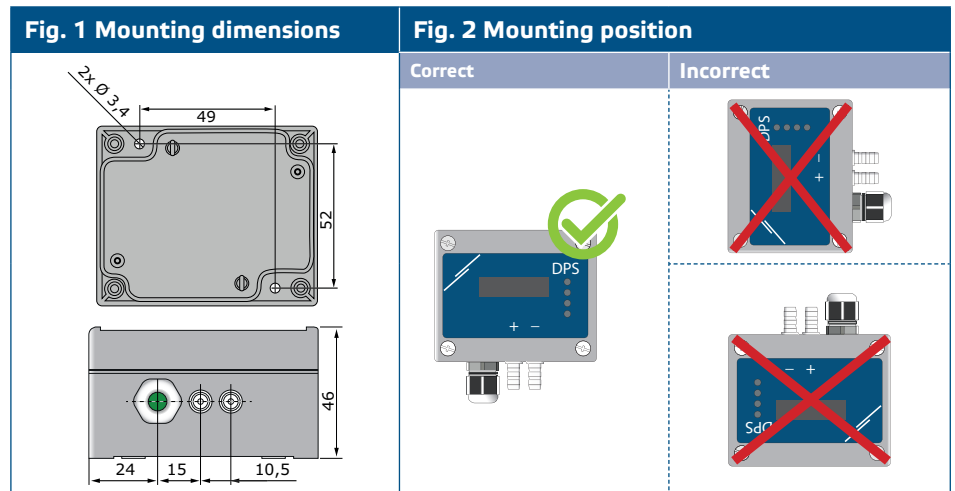

3. Insert the cable into the cable gland.
4. Crimp the RJ45 cable and plug it into the socket, see **Fig. 3** and section “Wiring and connections”.

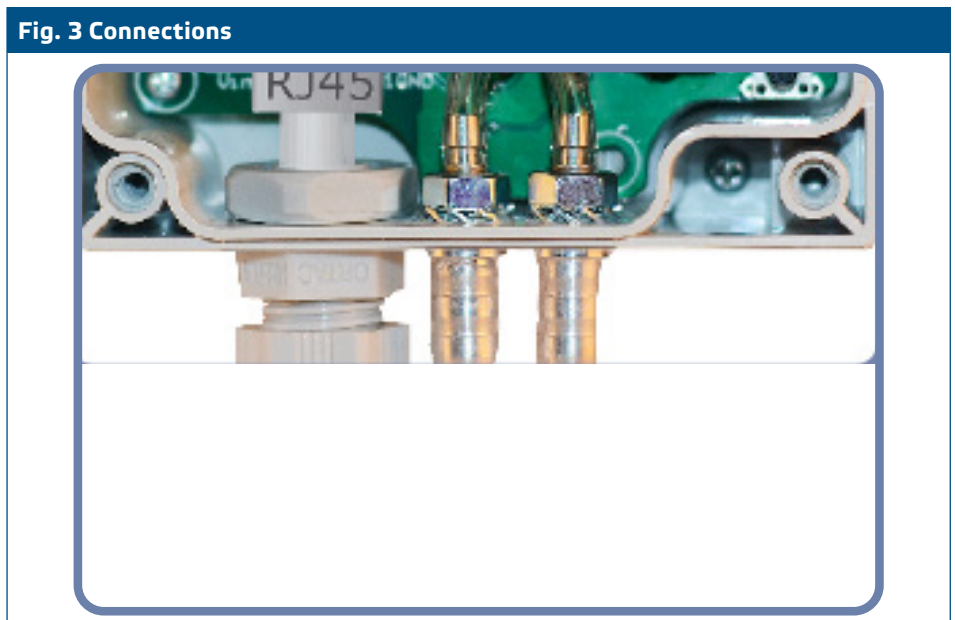

5. Connect the nozzles to the duct (see **Fig. 4**). Depending the application you must use a specific connection set to connect the nozzles of the unit to the duct:
 - 5.1 To control differential pressure, use PSET-QF or PSET-PVC set (pressure measurement is the unit default setting);
 - 5.2 To control volume flow, use PSET-PT Pitot tube connection set, PSET-QF or PSET-PVC connection set. If you use PSET-PT, you should enter the duct cross sectional area [cm²] in Modbus register 63. If you use PSET-QF or PSET-PVC, enter the K-factor of the fan (provided by the fan /motor manufacturer) in Modbus holding register 62.
In case the K-factor is not known, volume flow is calculated from a duct cross sectional area (holding register 63) multiplied by air velocity (Pitot air velocity (holding register 64) should be enabled and Pitot tube connected).
 - 5.3 To control air velocity, use PSET-PT set and enable Pitot tube air velocity via holding register 64. In this case the K-factor of the fan has to be 0.

Fig. 4 Connecting with accessories

Application 1: Controlling differential pressure [Pa] or volume flow [m³/h] using PSET-PVC (or PSET-QF)

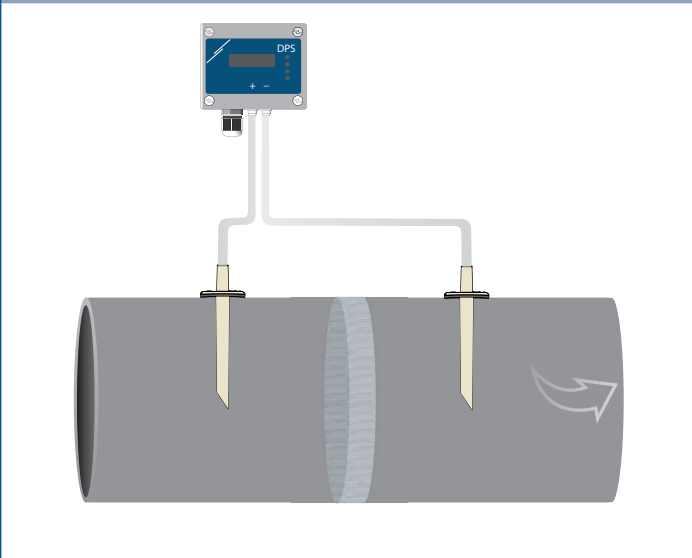

Application 2: Controlling volume flow [m³/h] or air velocity [m/s] using PSET-PT

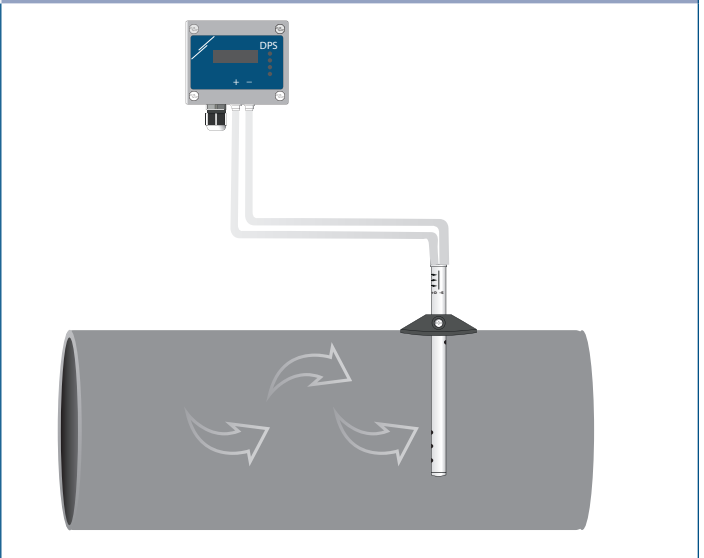

6. Switch on the power supply.

NOTE

For sensor calibration and Modbus registers reset procedures, refer to section "Operating instructions". Always calibrate the sensor before initial use.

Optional settings

To assure correct communication, the NBT needs to be activated in only two devices on the Modbus RTU network. If necessary, enable the NBT resistor via 3SModbus or Sensistant (Holding register 9).

Example 1

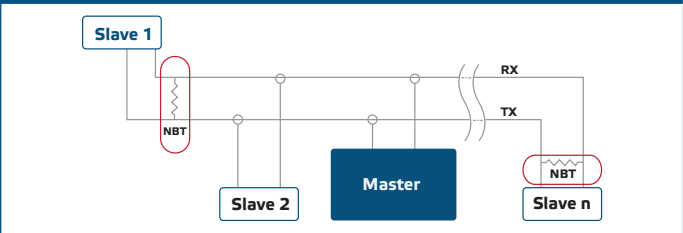

Example 2

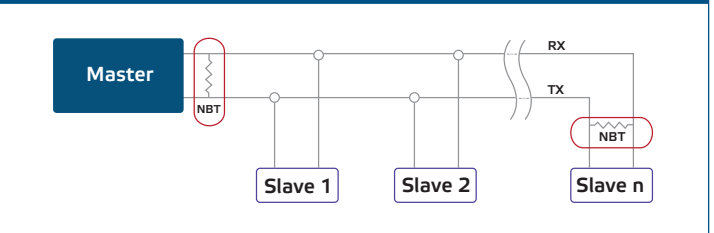

NOTE

On a Modbus RTU network, two bus terminators (NBTs) need to be activated.

- 7.** Put back the front cover and secure it with the screws.
- 8.** Customise the factory settings to the desired ones via the 3SModbus software or the Sensistant configurator. For the default factory settings, see *Modbus register map*.

NOTE

For the complete Modbus register data, refer to the product Modbus Register Map, which is a separate document attached to the article code on the website and contains the registers list. Products with earlier firmware versions may not be compatible with this list.

OPERATING INSTRUCTIONS

NOTE

For detailed information and settings, refer to the product Modbus register map, which is attached to the article code on our website.

Calibration procedure:

1. Disconnect the nozzles and make sure they are not clogged.
2. There are two options for starting the calibration process:
Either write "1" in holding register 70 or press button SW1 for 4 seconds until the green LED2 and yellow LED3 on the printed circuit board blink twice and release it immediately. If you hold SW1 for too long, you will reset the Modbus registers! (see **Fig. 8 Sensor calibration and Modbus register reset**).
3. After 2 seconds the green LED2 and yellow LED3 will blink twice once again to indicate that the calibration procedure has finished (see **Fig. 9 a Calibration Indication**).

ATTENTION

Make sure that the nozzles are disconnected and unobstructed.

Reset of Modbus registers procedure:

1. Press tact switch SW1 for 4 seconds until the green LED2 and yellow LED3 on the printed circuit board blink twice and hold the switch until both LEDs blink again three times (see **Fig. 8 Sensor calibration and Modbus register reset**).
2. The Modbus registers are reset to their default values (factory pre-set).
3. During the Modbus reset procedure the display will indicate "H" (See **Fig. 9 b Modbus reset indication**).

Fig. 8 Sensor calibration and Modbus register reset

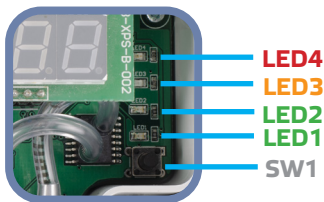
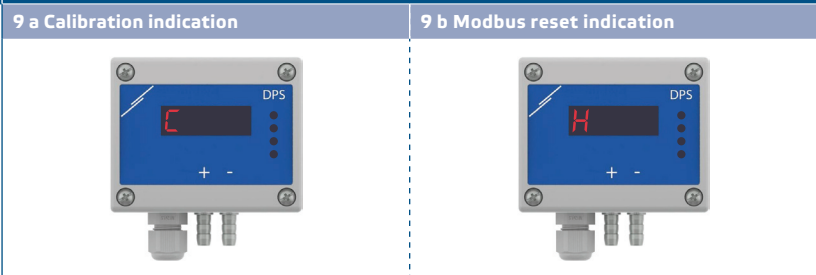

Fig. 9 Calibration & Modbus reset indication



Communication holding registers reset procedure:

1. Put the jumper onto pins 1 and 2 of the P4 connector for more than 20 s while the device is powered (see **Fig. 10**).

Fig. 10 Modbus holding register reset jumper

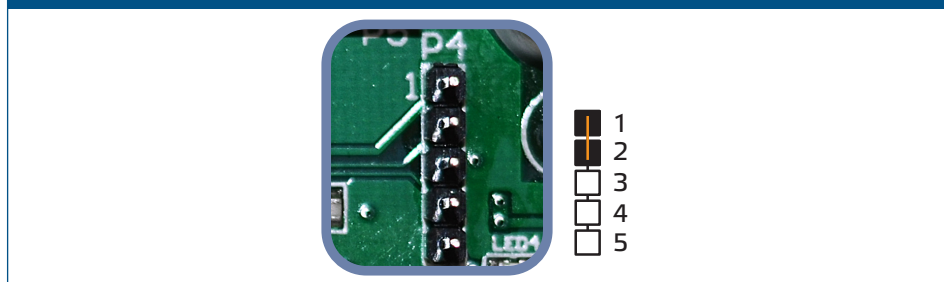

2. Modbus communication holding registers from 1 to 3 will be reset to the default values.
3. Remove the jumper.

ATTENTION

Correct reading of air velocity is only possible if it is enabled by holding register 64 (Pitot air velocity) and a transmitter is connected to the appropriate Pitot tube connection set (PSET-PTX-200).

Display settings

The display is enabled via writing "1" in holding register 91 (Measurement readout). Writing "0" will disable the display.

When the display is enabled, its mode depends on the value in holding register 61 (Operating mode). There are three display modes activated via writing the relevant figure in holding register 61 - see the table below:

Measurement readout enabled	
Value of holding register 61:	Display mode:
1	Differential pressure
2	Volume flow rate
3	Air velocity

1. Differential pressure display mode (see Fig. 11):

- 1.1 The LED display indicates the differential pressure level with a resolution of 0,1 Pa if the level is below 100 Pa. However, above 100 Pa, the resolution is 1 Pa. In both cases the 3SModbus software indicates the actual value. See Fig. 11 below.

Fig. 11 Differential pressure display

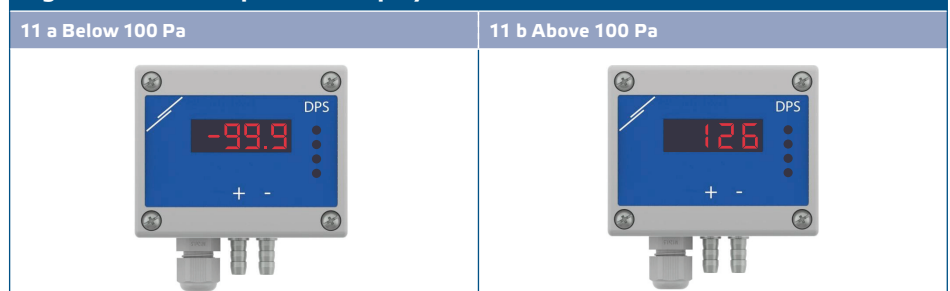

1.2 Out of range indication:

- ▶ The display shows "Lo" every 3 seconds in case the measured differential pressure is lower than the minimum limit of the control range set via the relevant holding register (see Fig. 12 a).
- ▶ In case the measured differential pressure is higher than the control range maximum limit, the display shows 'HI' every 3 seconds (see Fig. 12 b).

Fig. 12 Out of range indication

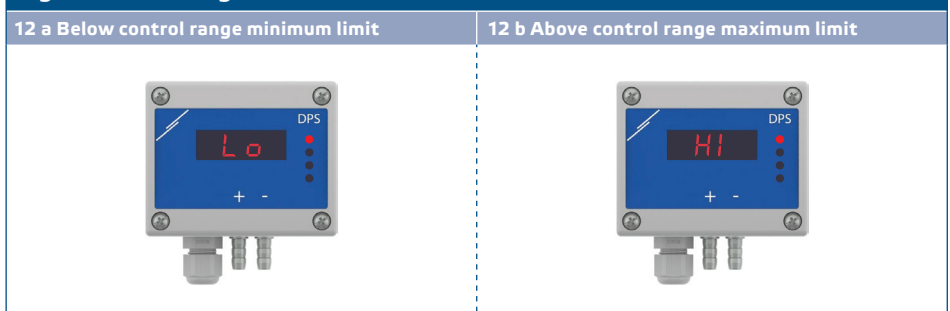

2. Air volume flow display mode:

- 2.1 Air volume flow rate within the range 0–9999 m³/h is displayed with a resolution of 1 m³/h. An example of displaying 100 m³/h is given in **Fig. 13 a** below.
- 2.2 Air volume flow rate above 10.000 m³/h is displayed divided by 1.000. An example of displaying 10.000 m³/h is given in **Fig. 13 b** below.

Fig. 13 Air volume flow and air velocity mode indications

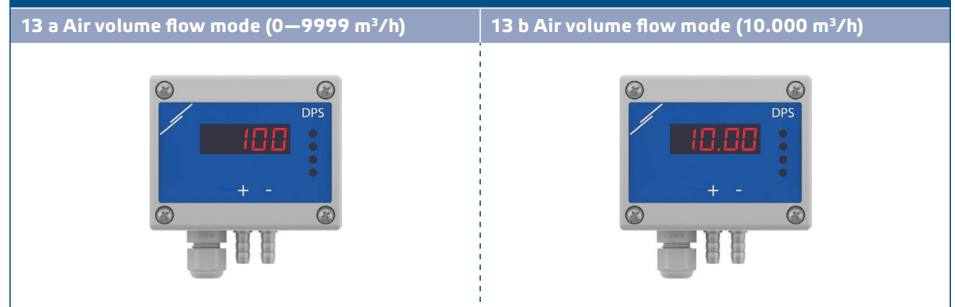

3. Air velocity display mode:

- 3.1 Air velocity is displayed with a resolution of 0,1 m/s. An example of displaying 1,0 m/s is given in **Fig. 14** below.

Fig. 14 Air velocity mode



 **NOTE**

Correct reading of air velocity is possible only if it is enabled by holding register 64 (Pitot air velocity) and a transmitter is connected to the appropriate Pitot tube connection set (PSET-PTX-200).

4. Sensor element failure indication:

In case of failure of sensor element or loss of communication with it, an 'Err' message is displayed and the red LED4 blinks. See **Fig. 15**.

Fig. 15 Sensor element error



 **NOTE**

Sensor failure condition is displayed only if the display is not in OFF mode (enabled and disabled via holding register 91).

TRANSPORT AND STORAGE

Avoid shocks and extreme conditions; stock in original packing.

WARRANTY AND RESTRICTIONS

Two years from the delivery date against defects in manufacturing. Any modifications or alterations to the product after the date of publication relieve the manufacturer of any responsibilities. The manufacturer bears no responsibility for any misprints or mistakes in this data.

MAINTENANCE

In normal conditions this product is maintenance-free. If soiled, clean with a dry or damp cloth. In case of heavy pollution, clean with a non-aggressive product. In these circumstances the unit should be disconnected from the supply. Pay attention that no fluids enter the unit. Only reconnect it to the supply when it is completely dry.