

AH2A1-6

ELECTRIC HEATING
CONTROLLER (SLAVE
DEVICE)

Mounting and operating instructions



Table of contents

SAFETY AND PRECAUTIONS	3
PRODUCT DESCRIPTION	4
INTENDED AREA OF USE	4
TECHNICAL DATA	4
STANDARDS	4
WIRING AND CONNECTIONS	5
OPERATIONAL DIAGRAM	5
MOUNTING INSTRUCTIONS IN STEPS	6
OPERATING INSTRUCTIONS	6
TROUBLESHOOTING	9
VERIFICATION OF INSTALLATION	10
TRANSPORT AND STORAGE	10
WARRANTY AND RESTRICTIONS	10
MAINTENANCE	10

SAFETY AND PRECAUTIONS



Read all the information in this manual, in the datasheet and in the Modbus Register Map before working with the product. For personal and equipment safety and for optimum product performance, make sure you fully understand the content before installing, using or servicing this product.



For safety and licensing (CE) reasons, unauthorised conversions and / or modifications of the product are inadmissible.



The product should not be exposed to abnormal conditions, such as extreme temperatures, direct sunlight or vibrations. Long-term exposure to chemical vapours in high concentration can affect the product performance. Make sure the work environment is as dry as possible and avoid condensation.



All installations must comply with local health and safety regulations and local electrical standards and approved codes. This product should only be installed by an engineer or a technician with expert knowledge of the product and safety precautions.



Avoid contact with energised electrical parts. Always disconnect the power supply before connecting, servicing or repairing the product.



Always check that you are connecting the correct power supply to the product and use wires of the correct characteristics and cross-section. Make sure all screws and nuts are properly tightened and fuses (if any) are in place.



Consideration should be given to recycling the equipment and packaging. These should be disposed of in accordance with local and national laws and regulations.



If there are questions that are not answered, contact your technical support or consult a professional.

PRODUCT DESCRIPTION

The AH2A1-6 is an electric heating controller for single-phase or two-phase electric heating elements.

- Main characteristics:
 - ▶ selectable analogue input: 0–10 VDC / 0–20 mA
 - ▶ selectable analogue output: 0–10 VDC / 0–20 mA
 - ▶ input for external timer for day / night mode (NO contact)
 - ▶ input for remote on/off switch (NC contact)
 - ▶ input for external potentiometer
 - ▶ remote on and off switching mode
- Advanced key features:
 - ▶ the controller uses TRIAC technology for precise fan speed control
 - ▶ the controller uses time-proportional control - the ratio between on- and off-time alters in order to fit the required heating power
 - ▶ designed to provide high quality of operation, accurate control and low life cycle costs

The controller functions as a Slave device and must be managed by a Master device in a network, e.g. controllers from the AH2C1-6 and AH2C1-6-500 series.

INTENDED AREA OF USE

- Control of heating systems
- For indoor use only

TECHNICAL DATA

- Supply voltage:
 - ▶ single phase: 230 (± 10 %) VAC / 50–60 Hz
 - ▶ two phase: 400 (± 10 %) VAC / 50–60 Hz
- Regulated output:
 - ▶ single phase: max. 3,2 kW (230 VAC)
 - ▶ two phase: 6 kW (400 VAC)
- Temperature measurement range: 0–50 °C
- Protection standard: IP54 (according to EN 60529)
- Red LED - power ON
- Green LED indicating output power
- Operating ambient conditions:
 - ▶ temperature: -20–40 °C
 - ▶ relative humidity: 5–85 % rH (non-condensing)

STANDARDS

- Low Voltage Directive 2014/35/EU 
 - ▶ EN 60730-1:2011 Automatic electrical controls for household and similar use - Part 1: General requirements
 - ▶ EN 60730-2-9:2010 Automatic electrical controls for household and similar use - Part 2-9: Particular requirements for temperature sensing controls
- EMC directive 2014/30/EU:
 - ▶ EN 61000-6-1:2007 Electromagnetic compatibility (EMC) - Part 6-1: Generic standards - Immunity for residential, commercial and light industrial environments
 - ▶ EN 61000-6-3:2007 Electromagnetic compatibility (EMC) - Part 6-3: Generic standards - Emission standard for residential, commercial and light-industrial environments Amendments A1:2011 and AC:2012 to EN 61000-6-3

- Commission Delegated Directive (EU) 2015/863 of 31 March 2015 amending Annex II to Directive 2011/65/EU of the European Parliament and of the Council as regards the list of restricted substances

WIRING AND CONNECTIONS

High voltage	
L	Power supply (230 (± 10 %) VAC or 400 (± 10 %) VAC)
N	Neutral
PE	Protective earth
N	Output for heater
H	
Low voltage	
Ao1	Analogue output (for connecting another slave device, e.g. AH2A1-6 or fan speed controller, repeating the analogue input signal from the master)
GND	Common ground for analogue input and analogue output
Ai1	Analogue input - temperature set point reference
NO	Input - normally open contact for remote ON / OFF switching (NO contact)
GND	GND for NO and NC input contacts
NC	Input - normally closed contact for remote ON / OFF switching (NC contact)
/B	Modbus RTU (RS485) communication, signal /B
A	Modbus RTU (RS485) communication, signal A
GND	Modbus RTU (RS485), ground

OPERATIONAL DIAGRAM

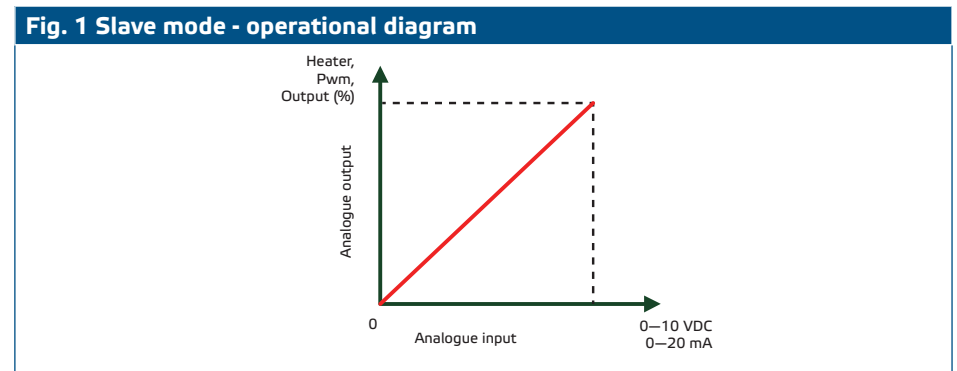

ATTENTION

The graphical picture shows the relation between the input signal and the PWM output to the heater. The PWM output to the heater follows the analogue input signal (e.g. Ai1 of 7 VDC = 70% PWM output to the heater).

MOUNTING INSTRUCTIONS IN STEPS

Before you start mounting the unit, read carefully **"Safety and precautions"** section. Choose a smooth surface for installation (e.g. a wall, a panel, etc.).

ATTENTION

Before mounting the device switch off the mains supply.

Follow these steps:

1. Turn off the power supply.
2. Unscrew the cover and open the controller. Mind the ribbon that connects the two printed circuit boards.
3. Insert the high voltage cables through the grommets and connect them according to the wiring diagram.

Fig. 2 Mounting dimensions

Article code	A	B	C	D	E	F
AH2A1-6	202 mm	115 mm	63 mm	102 mm	140 mm	Ø 4,60 mm

Fig. 3 Mounting position

Correct	Incorrect

4. Fix the unit onto the wall or panel using the provided screws and dowels. Mind the correct mounting position and mounting dimensions, as shown in **Fig. 2** and **Fig. 3**.
5. Insert the low voltage cables through the cable glands and connect them to the relevant terminals (refer to chapter **Operating instructions** below for further details).
6. Put back the cover and secure it with the screws.
7. Switch on the mains supply.

OPERATING INSTRUCTIONS

The controller can operate as a Slave device only, i.e. as an expansion unit. It can be controlled via Modbus or, in case you do not intend to use Modbus, adjust the parameters via the DIP switches (see **Fig. 6** below).

Follow these steps:

1. Connect the mains supply to L, N and Pe.
2. Connect the heater to the output terminal block - terminals N and H.
3. Connect the unit to a master device (e.g. AH2C1-6) by inserting the low voltage cables through one of the cable glands and connect them to GND and Ai1 of the terminal block.

Fig. 4 Basic wiring and connections

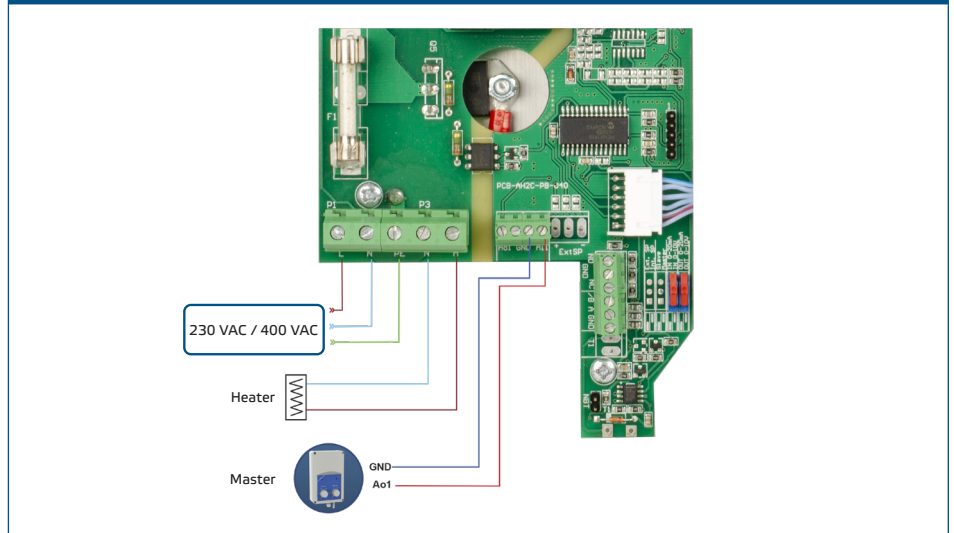

4. When used, the PWM output to the heater follows the analogue input signal. You can switch between 0–10 VDC or 0–20 mA via DIP switch 1 (see **Fig. 6 DIP switches**).
5. Your device is now ready to control your electric heater based on the signal sent by the master device. However, if you intend to use the additional control options provided by the device, proceed to connecting the external equipment as specified in *Additional control options*.

Additional control options (see Fig. 5)

1. **Modbus RTU communication** - AH2A1-6 can be controlled and all settings can be done via Modbus RTU communication. If you intend to use this option, you should connect the unit to a computer with installed 3SModbus application via the /B, A and GND terminals. You can download the 3SModbus application from Sentera’s website for free. The operating mode of the controller - Standalone or Modbus mode - is selected via Holding register 7 (see **Modbus register map**). Modbus mode disables the DIP switch settings.
2. **Remote ON / OFF** - terminals NC and GND. You can connect an external switch to turn the controller on and off remotely. When the connection between the NC and GND terminals is interrupted, the controller stops and the output is set to zero; therefore the AH2A1-6 features a factory installed bridge between these terminals. Remote ON / OFF can only be disabled via Modbus (see **Modbus registers map**, attached to the article code on the website).
3. **Analogue output** - terminals Ao1 and GND. The analogue output repeats the PWM output to the heater, i. e. a 7 VDC analogue output signal is translated into a 70% PWM output to the heater, an 8 VDC Ao signal is translated into an 80% PWM output to the heater, etc. You can switch between 0–10 VDC or 0–20 mA via DIP switch 2 (see **Fig. 6 DIP switches**) or Modbus RTU.

Fig. 5 Additional options

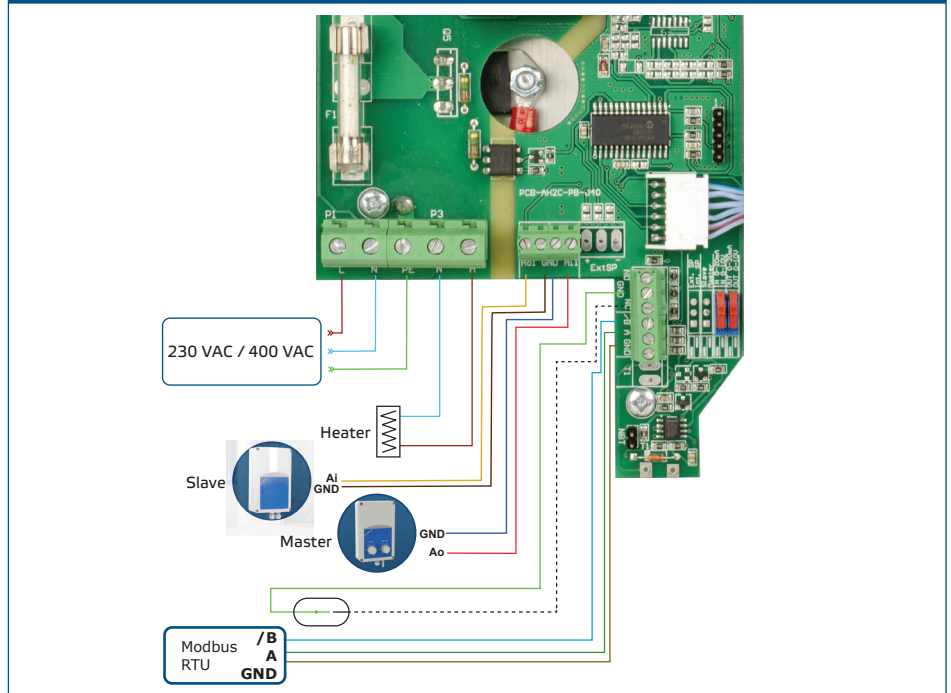

4. Set the DIP switches (**Fig. 6**) in the relevant positions to select the input and output type.

Fig. 6 DIP switch settings

1 - Input type		0–20 mA
		0–10 VDC
2 - Output type		0–20 mA
		0–10 VDC

Modbus communication

Modbus communication can be used to control AH2A1-6 devices remotely or from a Master controller (e.g. a computer with Sentera’s free 3SModbus software installed). When Modbus mode is selected (via holding register 7), the controller does not follow the DIP switch settings and all options are selected via Modbus.

Optional settings

The Network Bus Terminator (NBT) is used to set the device and by default the NBT is disconnected. It is put manually onto the pins to be connected (see **Fig. 7**). To assure correct communication, the NBT jumper needs to be activated in only two devices on the Modbus RTU network (see **Example 1** and **Example 2**).

Fig. 7 NBT jumper

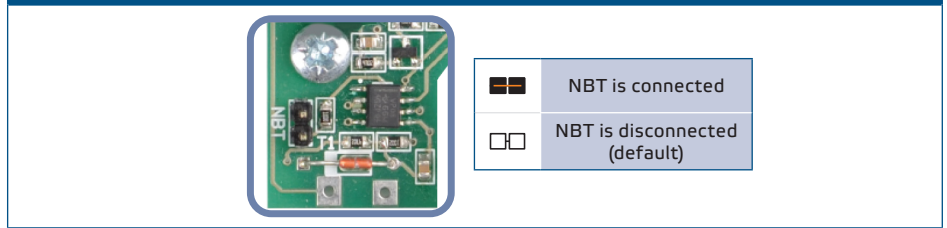

Example 1

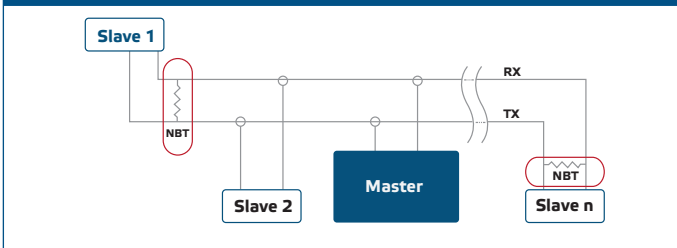

Example 2

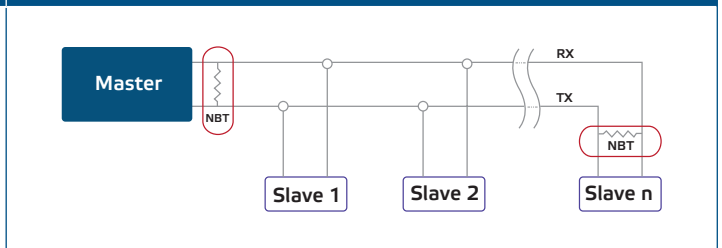

ATTENTION

On a Modbus RTU network, two bus terminators (NBTs) need to be activated

TROUBLESHOOTING

After finishing installation of the product, if the device is still not operating, check if there are not any serious external damages to the enclosure. In case of faulty operation, please check if:

- the right voltage is applied;
- the communication through Modbus RTU is not interrupted;
- the controller is not overheated;
- all connections are correct;
- the wires are the correct ones and not damaged;
- the cables are tightly plugged in;
- the applied supply voltage is correct;
- the motor to be regulated is functioning.

Then proceed with the following steps:

- disconnect the mains supply before servicing the product;
- wait for the controller to cool if it's overheated;
- check the connections and, if necessary, rearrange the wires;
- check if the right supply voltage is applied. If needed, measure the supply voltage to see if it's below or way above the maximum required supply voltage;
- restart the communication through Modbus RTU and rearrange the wires.
- Check if the cables, you will use are not damaged and tightly plugged in.

VERIFICATION OF INSTALLATION

ATTENTION

Use only tools and equipment with non-conducting handles when working on electrical devices.

After switching on the power supply the red LED should be on to indicate that the unit is supplied. The green LED indicates that the output is active. If this is not the case, check the connections.

TRANSPORT AND STORAGE

Avoid shocks and extreme conditions. Stock in original packaging.

WARRANTY AND RESTRICTIONS

Two years from the delivery date against defects in manufacturing. Any modifications or alterations to the product relieve the manufacturer of any responsibilities. The manufacturer bears no responsibility for any misprints or mistakes in this data.

MAINTENANCE

In normal conditions this product is maintenance-free. If soiled, clean with a dry or damp cloth. In case of heavy pollution, clean with a non-aggressive product. In these circumstances the unit should be disconnected from the supply. Pay attention that no fluids enter the unit. Only reconnect it to the supply when it is completely dry.