

AH2A1-6 | ELECTRONIC HEATING CONTROLLER (SLAVE DEVICE)

Mounting and operating instructions



Table of contents

SAFETY AND PRECAUTIONS	3
PRODUCT DESCRIPTION	4
INTENDED AREA OF USE	4
TECHNICAL DATA	4
STANDARDS	4
WIRING AND CONNECTIONS	5
OPERATIONAL DIAGRAMS	5
MOUNTING INSTRUCTIONS IN STEPS	6
OPERATING INSTRUCTIONS	6
VERIFICATION OF INSTALLATION	9
TRANSPORT AND STORAGE	9
WARRANTY AND RESTRICTIONS	9
MAINTENANCE	9

SAFETY AND PRECAUTIONS



Read all the information, the datasheet, mounting and operating instructions and study the wiring and connection diagram before working with the product. For personal and equipment safety and for optimum product performance, make sure you entirely understand the contents before installing, using or maintaining this product.



For safety and licensing (CE) reasons, unauthorised conversion and / or modifications of the product are inadmissible.



The product should not be exposed to abnormal conditions, such as: extreme temperatures, direct sunlight or vibrations. Long-term exposure to chemical vapours in high concentration can affect the product performance. Make sure the work environment is as dry as possible and avoid condensation.



All installations shall comply with local health and safety regulations and local electrical standards and approved codes. This product can only be installed by an engineer or a technician, who has expert knowledge of the product and safety precautions.



Avoid contacts with energised electrical parts. Always disconnect the power supply before connecting, servicing or repairing the product.



Always verify that you apply appropriate power supply to the product and use appropriate wire size and characteristics. Make sure that all the screws and nuts are well tightened and fuses (if any) are fitted well.



Recycling of equipment and packaging should be taken into consideration and these should be disposed of in accordance with local and national legislation / regulations.



In case there are any questions that are not answered, please contact our technical support or consult a professional.

PRODUCT DESCRIPTION

AH2A1-6 are electric heating controllers for single-phase or two-phase electric heating. They are used as slave devices and need a "master" device (AH2C1-6, AH2C1-6-500, etc.) to control them. The series utilise time-proportional control: the ratio between on-time and off-time alters in order to fit the heating requirements. The current is triac-switched, which minimises wear and tear, while enhanced control accuracy reduces energy costs.

INTENDED AREA OF USE

- Control of heating systems
- For indoor use only

TECHNICAL DATA

- Modbus RTU communication
- Input for external timer for day / night mode (NO contact)
- Input for remote on/off switch (NC contact)
- Input for external potentiometer
- Supply voltage:
 - ▶ single phase: 230 ($\pm 10\%$) VAC / 50–60 Hz
 - ▶ two phase: 400 ($\pm 15\%$) VAC / 50–60 Hz
- Regulated output:
 - ▶ single phase: max. 3,2 kW (230 VAC)
 - ▶ two phase: 6 kW (400 VAC)
- Temperature measurement range: 0–50 °C
- Analogue output: 0–10 VDC / 0–20 mA
- Analogue input: 0–10 VDC / 0–20 mA
- Protection standard: IP54 (according to EN 60529)
- Red LED - power ON
- Green LED - output power on
- Operating ambient conditions:
 - ▶ temperature: -20–40 °C
 - ▶ rel. humidity: 5–85 % rH (non-condensing)

STANDARDS

- Low Voltage Directive 2014/35/EU 
 - ▶ EN 60730-1:2011 Automatic electrical controls for household and similar use - Part 1: General requirements
 - ▶ EN 60730-2-9:2010 Automatic electrical controls for household and similar use - Part 2-9: Particular requirements for temperature sensing controls
- EMC directive 2014/30/EU:
 - ▶ EN 61000-6-1:2007 Electromagnetic compatibility (EMC) - Part 6-1: Generic standards - Immunity for residential, commercial and light industrial environments
 - ▶ EN 61000-6-3:2007 Electromagnetic compatibility (EMC) - Part 6-3: Generic standards - Emission standard for residential, commercial and light-industrial environments Amendments A1:2011 and AC:2012 to EN 61000-6-3
- RoHs Directive 2011/65/EU

WIRING AND CONNECTIONS

High voltage	
L	Power supply (230 (± 10 %) VAC or 400 (± 15 %) VAC)
N	Neutral
PE	Protective earth
N	Output for heater
H	
Low voltage	
Ao1	Analogue output (for connecting another slave device, e.g. AH2A1-6 or fan speed controller, repeating the analogue input signal from the master)
GND	Common ground for analogue input and analogue output
Ai1	Analogue input - temperature setpoint reference
NO	Input - normally open contact for remote ON / OFF switching (NO contact)
GND	GND for NO and NC input contacts
NC	Input - normally closed contact for remote ON / OFF switching (NC contact)
/B	Modbus RTU (RS485) communication, signal /B
A	Modbus RTU (RS485) communication, signal A
GND	Modbus RTU (RS485), ground

OPERATIONAL DIAGRAMS

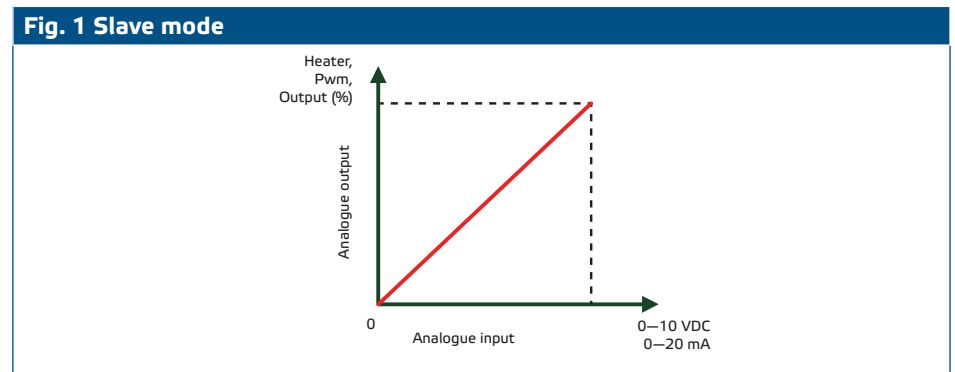

ATTENTION

The graphical picture shows the relation between the input signal and the PWM output to the heater. The PWM output to the heater follows the analogue input signal (e.g. Ai1 of 7 VDC = 70% PWM output to the heater).

NOTE

The AH2A1-6 controller can be used only as a Slave device. Use AH2C1-6-500 and AH2C1-6 as Master-type devices to control the slave device.

MOUNTING INSTRUCTIONS IN STEPS

Before you start mounting the unit, read carefully **"Safety and precautions"** section. Choose a smooth surface for installation (e.g. a wall, a panel, etc.).

ATTENTION

Before mounting the device switch off the mains supply.

Follow these steps:

1. Make sure the main supply is switched off before you start working with the product.
2. Unscrew the cover and open the controller. Mind the ribbon that connects the two printed circuit boards.
3. Insert the high voltage cables through the grommets and connect them according to the wiring diagram.

Fig. 2 Mounting dimensions

Article code	A	B	C	D	E	F
AH2A1-6	202 mm	115 mm	63 mm	102 mm	140 mm	Ø 4,60 mm

Fig. 3 Mounting position

Correct	Incorrect

4. Fix the unit onto the wall or panel using the provided screws and dowels. Mind the correct mounting position and mounting dimensions, as shown in **Fig. 2** and **Fig. 3**).
5. Insert the low voltage cables through the cable glands and connect them to the relevant terminals (refer to section **Operating instructions** below for further details).
6. Put back the cover and secure it with the screws.
7. Switch on the mains supply.

OPERATING INSTRUCTIONS

The controller can operate as a Slave device only, i.e. as an expansion unit. It can be controlled via Modbus or, in case you do not intend to use Modbus, you can set the parameters via the DIP switches (see **Fig. 6** below).

Follow these steps (see Fig. 3):

1. Connect the mains supply to L, N and Pe.
2. Connect the heater to the output terminal block - terminals N and H.
3. Connect the unit to a master device (e.g. AH2C1-6) by inserting the low voltage cables through one of the cable glands and connect them to GND and Ai1 of the terminal block.

Fig. 4 Basic wiring and connections

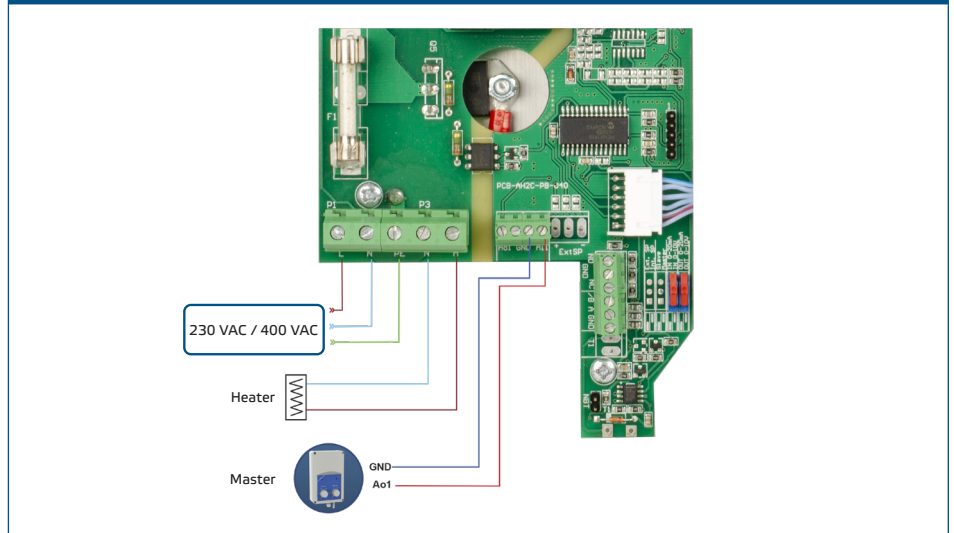

4. When used, the PWM output to the heater follows the analogue input signal. You can switch between 0–10 VDC or 0–20 mA via DIP switch 1 (see **Fig. 6 DIP switches**).
5. Your device is now ready to control your electric heater based on the signal sent by the master device. However, if you intend to use the additional control options provided by the device, proceed to connecting the external equipment as specified in *Additional control options*.

Additional control options (see Fig. 5)

1. **Modbus RTU communication** - AH2A1-6 can be controlled and all settings can be done via Modbus RTU communication. If you intend to use this option, you should connect the unit to a computer with installed 3SModbus application via the /B, A and GND terminals. You can download the 3SModbus application from Sentera’s website for free. The operating mode of the controller - Standalone or Modbus mode - is selected via Holding register 7 (see **Modbus register map**). Modbus mode disables the DIP switch settings.
2. **Remote ON / OFF** - terminals NC and GND. You can connect an external switch to turn the controller on and off remotely. When the connection between the NC and GND terminals is interrupted, the controller stops and the output is set to zero; therefore the AH2A1-6 features a factory installed bridge between these terminals. Remote ON / OFF can only be disabled via Modbus (see **Modbus registers map**, attached to the article code on the website).
3. **Analogue output** - terminals Ao1 and GND. The analogue output repeats the PWM output to the heater, i. e. a 7 VDC analogue output signal is translated into a 70% PWM output to the heater, an 8 VDC Ao signal is translated into an 80% PWM output to the heater and etc. You can switch between 0–10 VDC or 0–20 mA via DIP switch 2 (see **Fig. 6 DIP switches**) or Modbus RTU.

Fig. 5 Additional options

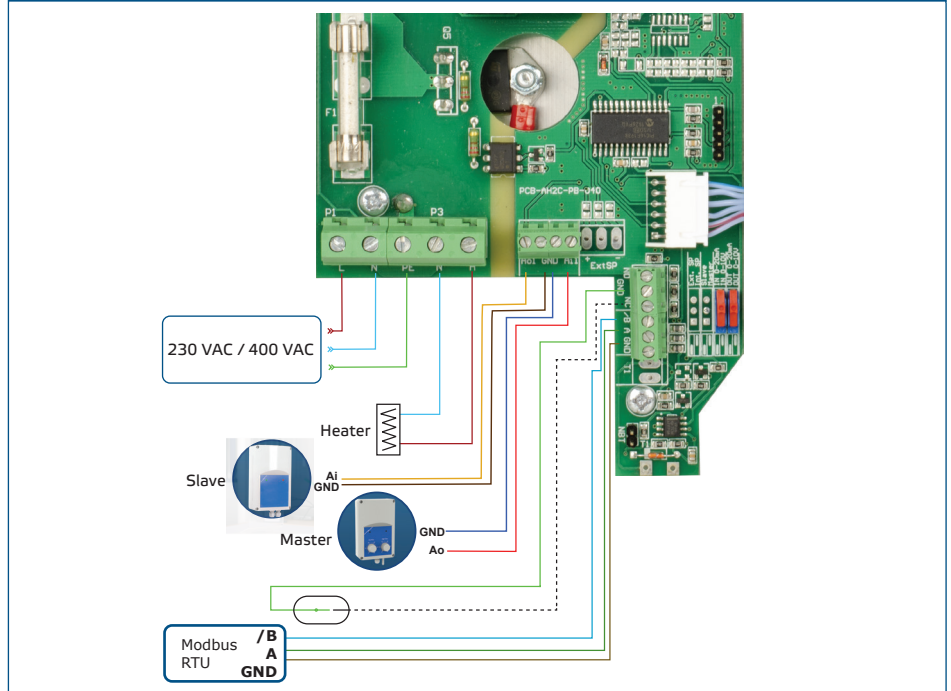

4. Set the DIP switches (**Fig. 6**) in the relevant positions to select the input and output type.

Fig. 6 DIP switch settings

1 - Input type		0–20 mA
		0–10 VDC
2 - Output type		0–20 mA
		0–10 VDC

Modbus communication

Modbus communication can be used to control AH2A1-6 devices remotely or from a Master controller (e.g. a computer with installed Sentera’s free 35Modbus software). When Modbus mode is selected (via holding register 7), the controller does not follow the DIP switch settings and all options are selected via Modbus.

Optional settings

The Network Bus Terminator (NBT) is used to set the device and by default the NBT is disconnected. It is put manually onto the pins to be connected (see **Fig. 7**). To assure correct communication, the NBT jumper needs to be activated in only two devices on the Modbus RTU network (see **Example 1** and **Example 2**).

Fig. 7 NBT jumper

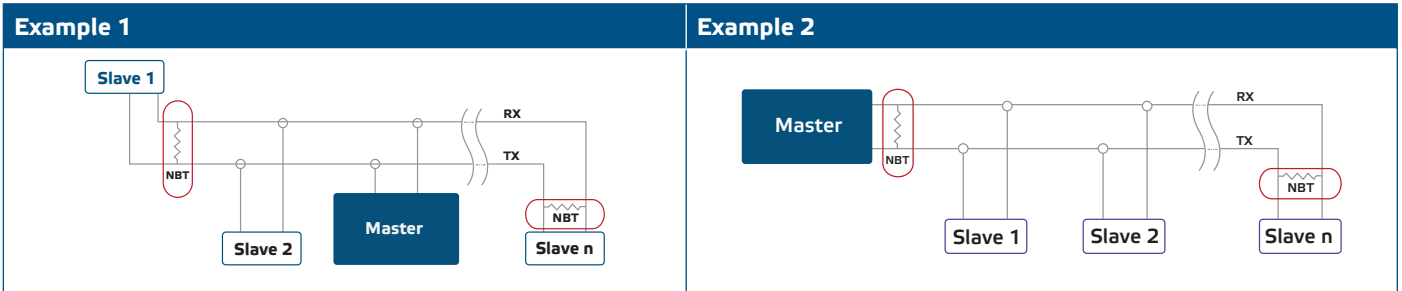
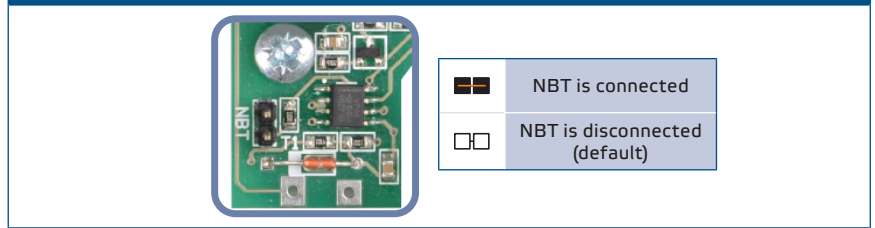

ATTENTION

On a Modbus RTU network, two bus terminators (NBTs) need to be activated

VERIFICATION OF INSTALLATION

ATTENTION

Use only tools and equipment with non-conducting handles when working on electrical devices.

After switching on the power supply the red LED should be on to indicate that the unit is supplied. The green LED indicates that the output is active. If this is not the case, check the connections.

TRANSPORT AND STORAGE

Avoid shocks and extreme conditions. Stock in original packing.

WARRANTY AND RESTRICTIONS

Two years from the delivery date against defects in manufacturing. Any modifications or alterations to the product relieve the manufacturer of any responsibilities. The manufacturer bears no responsibility for any misprints or mistakes in this data.

MAINTENANCE

In normal conditions this product is maintenance-free. If soiled, clean with a dry or damp cloth. In case of heavy pollution, clean with a non-aggressive product. In these circumstances the unit should be disconnected from the supply. Pay attention that no fluids enter the unit. Only reconnect it to the supply when it is completely dry.