

W-KD

Rubber grommet



Description

The W-KD-XX-M20 general-purpose grommets provide a tight seal for cables. These grommets offer IP67 protection, ensuring complete protection against dust ingress and temporary immersion in water. They are suitable for secure cable routing and anchoring, which makes them ideal for various applications.

The grommets are manufactured using high-quality TPV (Thermoplastic Vulcanizate) rubber, which offers durability and flexibility. They are available in three-colour options: white, grey and black, allowing users to choose the most suitable option for their specific needs.

These cable grommets provide several benefits:

- **Effective sealing:** The IP67 rating ensures a watertight and dust-proof seal, protecting the cables from environmental factors.
- **Versatility:** They can be used for various cable management applications, including external installations.
- **Easy installation:** The grommets are designed for simple and tool-free installation, making them user-friendly.
- **Vibration resistance:** They can withstand vibrations, ensuring long-term stability.
- **Dual functionality:** The grommets can also serve as blanking plugs until a cable is installed.

By using the W-KD-XX-M20 grommets, users can ensure proper cable management, protection and organisation in their projects.

Key Features

- **Superior Sealing:**
 - Dust and water-resistant
 - Maintains seal integrity before and after cable installation without additional plugs
- **Compact Design:**
 - M20 metric size
 - Minimal protrusion, ideal for space-constrained applications
- **Consistent Quality:**
 - Manufactured through automated production processes
 - Ensures uniform quality and evenness across all units
- **Durability:**
 - Resistant to common fluids and solvents
 - Suitable for challenging environments
- **User-Friendly Installation:**
 - Quick and easy to install
 - No need for threaded holes or locknuts
 - Simplifies the installation process
- **Cost-Effective:**
 - Provides a budget-friendly solution for cable management and protection
- **Versatility:**
 - Suitable for various applications across different industries

These features make the W-KD-XX-M20 grommets an excellent choice for projects requiring reliable cable protection and management in compact spaces, while also offering ease of installation and cost-effectiveness.

Area of Use

- For use in areas where cables and wires need to be safely put through the walls of enclosures

Technical Specifications

Material	Rubber TPV
Protection standard	IP67 (according to EN 60529)
Temperature range	-60—135 °C

Standards

- Commission Delegated Directive (EU) 2015/863 of 31 March 2015 amending Annex II to Directive 2011/65/EU of the European Parliament and of the Council as regards the list of restricted substances



Article Codes

Article code	Internal thread	Colour
W-KD-WH-M20	7–10 mm	white (RAL 9010)
W-KD-LG-M20		grey (RAL 7035)
W-KD-BK-M20		black (RAL 9005)

Dimensions

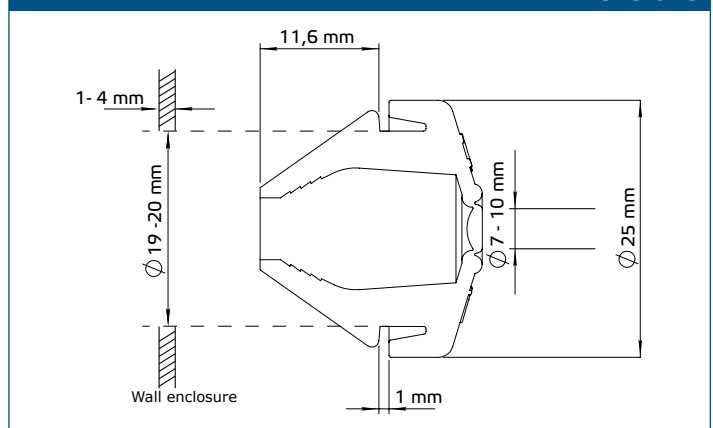

Application Example



In this application example, white rubber grommets with article code W-KD-WH-M20 are used to ensure tight sealing and protection of the connected cables.

W-KD

Rubber grommet



Global Trade Item Numbers (GTIN)

Article	Unit	Box
W-KD-WH-M20	05401003008393	05401003501894
W-KD-LG-M20	05401003008386	05401003501887
W-KD-BK-M20	05401003008379	05401003501870

Packaging

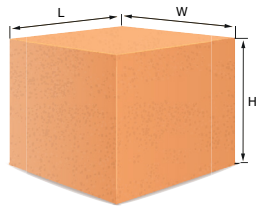
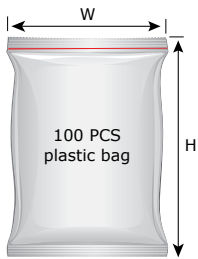

Article	Packaging	Length [mm]	Width [mm]	Height [mm]	Net weight	Gross weight
W-KD-XX-M20	Plastic bag (100 pcs.)	-	190	250	0,5 kg	0,51 kg
	Box (1000 pcs.)	430	300	190	5 kg	5,4 kg