

SFPR4

Transformer fan speed controller with gas flow control



The SFPR4 series are transformer fan speed controllers, which regulate the rotational speed of three-phase 400 V motors by varying the output voltage in five steps. The series feature TK monitoring for thermal motor protection and an input for remote start/stop. The relay output can control an external gas supply valve. Gas supply will be enabled only when the exhaust fan is active. If no air flow is detected within 60 seconds, the gas flow will be stopped.

Key features

- Wide power range
- 5-step rotary switch for manual control with an off-position
- Sensing input for a flow detector (or pressure sensor)
- Potential free relay output (NC/COM/NO), controlled by a flow / pressure sensing input (to switch a gas valve / actuator)
- Input for remote start/stop or thermostat
- LED status indication
- Auto restart after power failure

Technical specifications

Power supply	3x400 VAC ± 10% / 50–60 Hz	
Unregulated output	230 VAC / 2 A	
Protection standard	IP54 (according to EN 60529)	
Ambient operating conditions	Temperature	-20–35 °C
	Rel. humidity	5–95 % rH (non-condensing)



Operational diagram

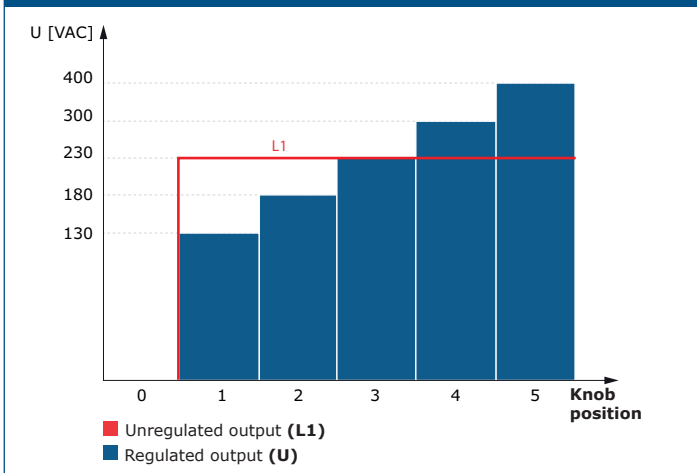

Article codes

Article code	Rated max. current [A]
SFPR4-15L40	1,5
SFPR4-25L40	2,5
SFPR4-40L40	4,0
SFPR4-60L40	6,0
SFPR4-80L40	8,0

Area of use

- Fan speed control of three-phase voltage controllable motors in ventilation systems
- For indoor use only

Wiring and connections

R, S, T	Supply voltage 3 x 400 VAC ± 10% / 50–60 Hz
N	Neutral
PE	Earth terminal
L1, N	Unregulated output, 230 VAC / 2 A
U, V, W	Regulated output to the motor (0 / 130 / 180 / 230 / 300 / 400 VAC ± 5 %)
PE	Earth terminal
COM, NO, NC	Relay output to control a gas valve (contact ratings: 230 VAC / 6 A)
TK, TK	TK monitoring for thermal motor protection
NC, NC	Input for remote ON/OFF switching via an external switch or thermostat, normally closed
FL, FL	Input for gas flow or pressure sensor, normally closed
Connections	Cable gland clamping range: 8–13 mm; Cable cross section: depends on the article

Voltage

Knob position	0	1	2	3	4	5
Wires						
Regulated output [VAC]						
L40 version	0	130	180	230	300	400
Unregulated output [VAC]						
L1	0	230	230	230	230	230

SFPR4

Transformer fan speed controller with gas flow control



Wiring diagrams

230 VAC gas valve / actuator supplied from L1 / N terminals with external fuse protection on phase R (max. 6 A)

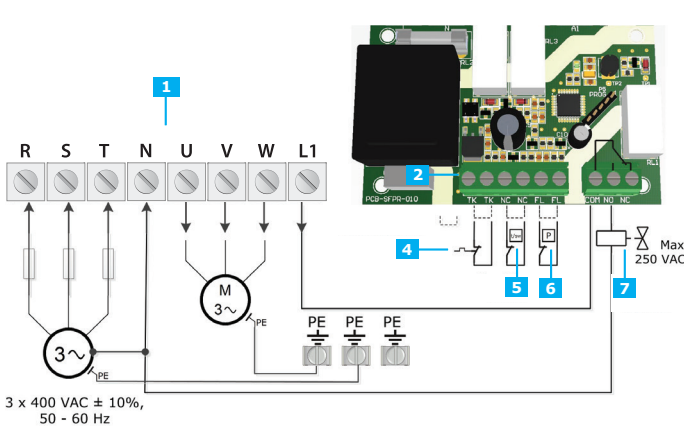

Gas valve / actuator supplied from external 24 VDC supply

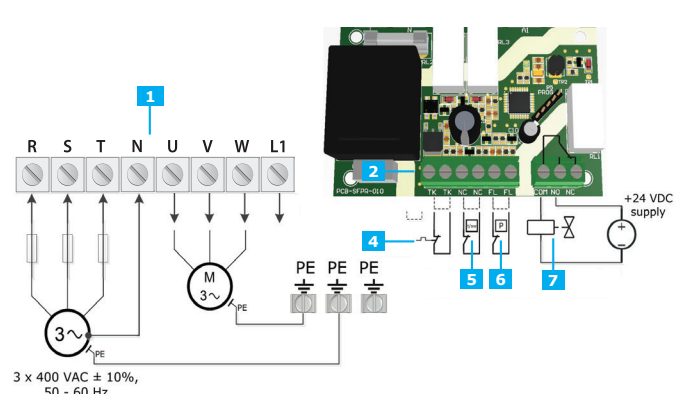

1 - Power terminal block	
2 - Control terminal block	
3 - Earth terminals	
4 - Thermal contact	TK contacts for thermal motor protection
5 - Run/stop switch	Input for remote start/stop
6 - Flow/pressure switch	Input for gas flow or pressure switch
7 - Gas valve actuators	Relay output to control gas valve

Fixing and dimensions

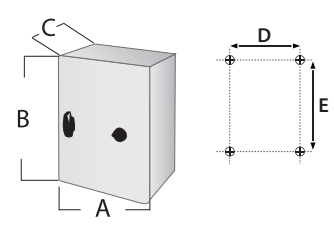

Article code	A [mm]	B [mm]	C [mm]	D [mm]	E [mm]	Enclosure
SFPR4-15L40	325	300	175	255	255	sheet steel (RAL7035, polyester powder coating)
SFPR4-25L40	325	300	175	255	255	
SFPR4-40L40	425	300	175	255	355	
SFPR4-60L40	425	300	235	255	355	
SFPR4-80L40	425	300	235	255	355	

Packaging

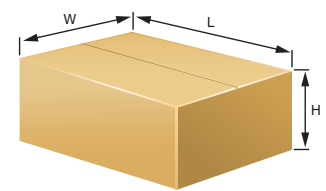

Article	Packaging	Length [mm]	Width [mm]	Height [mm]	Net weight [kg]	Gross weight [kg]
SFPR4-15L40	Unit (1 pc.)	340	310	200	11,7 kg	12,2 kg
SFPR4-25L40	Unit (1 pc.)	340	310	200	13,1 kg	13,6 kg
SFPR4-40L40	Unit (1 pc.)	440	310	200	18,2 kg	18,8 kg
SFPR4-60L40	Unit (1 pc.)	440	310	250	21,7 kg	22,3 kg
SFPR4-80L40	Unit (1 pc.)	440	310	250	27,2 kg	27,8 kg



SFPR4

Transformer fan speed controller with gas flow control

Standards

- Low Voltage Directive 2006/95/EC
- EN 61558-1:2005/A1:2009 - Safety of power transformers, power supplies, reactors and similar products - Part 1: General requirements and tests
- EN 61558-2-13:2009 - Safety of transformers, reactors, power supply units and similar products for supply voltages up to 100 V - Part 2-13: Particular requirements and tests for auto transformers and power supply units incorporating auto transformers
- WEEE Directive 2012/19/EU
- RoHS Directive 2011/65/EU



Global trade item numbers (GTIN)

Packaging	SFPR4-15L40	SFPR4-25L40	SFPR4-40L40	SFPR4-60L40	SFPR4-80L40
Unit	05401003014516	05401003014523	05401003014530	05401003014547	05401003014554