



ACDPH

Circular motorised damper with pressure control

ACDPH series are circular motorised dampers with integrated differential pressure control that regulate the air flow in duct systems. They measure the static pressure at one point of the ductwork and when pressure, volume flow or air velocity changes this is compensated by adjusting the position of the damper blade in order to achieve the desired pressure. This is how comfort ventilation is provided. The supply voltage is 24 VDC. All parameters are accessible via Modbus RTU communication.

Key features

- 24 VDC supply voltage via RJ45 connector or terminal block
- Modbus RTU communication via RJ45 connector or terminal block
- Built-in digital high resolution differential pressure sensor
- Compatible with SenteraWeb for remote control and online monitoring
- Fits circular air ducts with standard dimensions
- Holding registers to activate manually zero-point calibration and Modbus registers reset
- Damper blade can be placed in any position in accordance with the airflow direction with the overwrite function

Area of use

- Control air volume flow and temperature in order to provide comfort ventilation
- Regulate fresh air supply for each room separately

Technical specifications

Supply voltage	24 VDC (RJ45 (PoM) or terminal block)	
Operating range of the differential pressure sensor	0–1.000 Pa	
Max. actuator torque	5 Nm	
Operating air velocity range	0–12 m/s	
Power consumption	max. 2,4 VA	
Accuracy	±2 % of the operating range	
Damper blade airtightness	Class 4 (according to EN1751)	
Protection standard	IP54 (according to EN 60529)	
Enclosure	ABS 10GF, grey	
Ambient conditions	Temperature	-5–65 °C
	Rel. humidity	< 95 % rH (non-condensing)

Article codes

Article code	Duct diameter	I _{max}	Connection type
ACDPH-125	125 mm	100 mA	RJ45 or terminal block
ACDPH-160	160 mm		

Modbus registers



The Sensstant Modbus configurator allows you to easily monitor and/or configure Modbus parameters.

The parameters of the unit can be monitored / configured through the 3SMODBUS software platform. You can download it from the following link:

<https://www.sentera.eu/en/3SMCenter>

For more information about the Modbus registers, please refer to the Modbus Register Map of the product.



Settings and indications

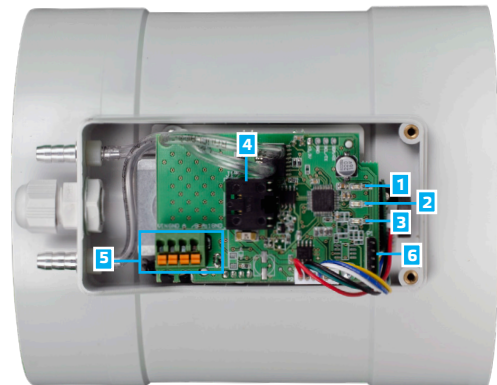

1 - Green LED 1	On	Damper blade is fully closed (zero position)
2 - Green LED 2	Blinking	Indicates normal operation of the damper
3 - Green LED 3	On	Damper blade is fully open (90 °)
4 - RJ45 socket		Modbus RTU communication and 24 VDC power supply can be connected via the RJ45 socket
5 - Terminal block		Modbus RTU communication, 24 VDC power supply and the control input can be connected via the terminal block
6 - PROG header, P1		Put a jumper onto pins 1 and 2 and wait for at least 15 seconds to reset the Modbus communication parameters
		Put a jumper onto pins 3 and 4 and restart the supply to enter bootloader mode

Note: When the actuator is in bootloader mode, LED 3 is flashing. During the firmware download, LED 2 and LED 3 are flashing simultaneously.



ACDPH

Circular motorised damper with pressure control

Operational diagram

PI control (operating mode selected – differential pressure, volume flow rate or air velocity)

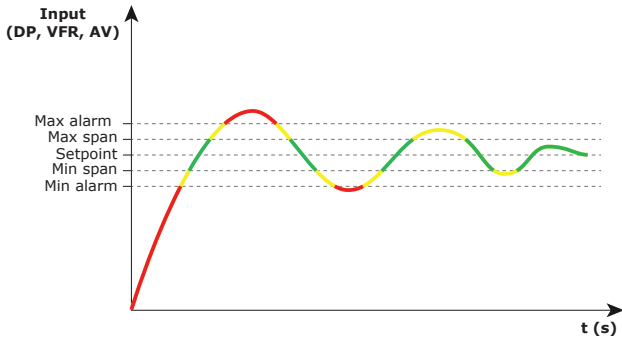

PI control example at different Kp

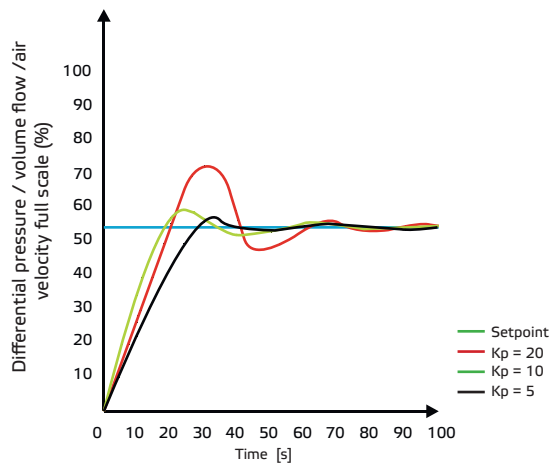

Blade position in overwrite mode

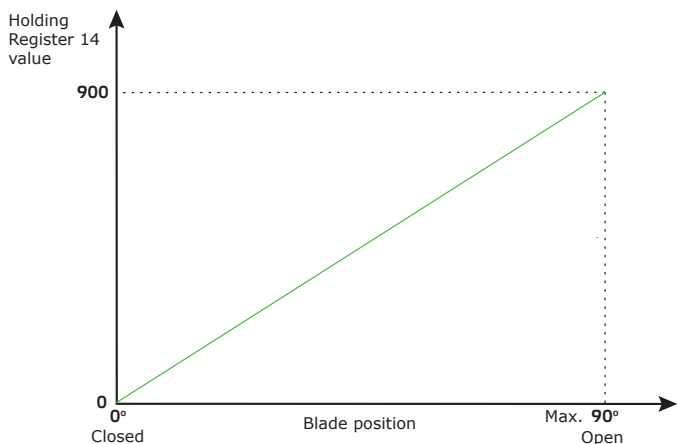

Air flow characteristics

Article Code		ACDPH-125				ACDPH-160				
Average velocity V_k (m/s)		3	6	9	12	3	6	9	12	
Air Volume Q (m ³ /h)		130	263	396	530	216	434	652	871	
$p_s = 125$ Pa	Lw (dB/Oct)	63 Hz	38	46	50	57	41	49	53	59
		125 Hz	40	54	55	57	42	56	57	58
		250 Hz	36	50	52	55	39	51	52	57
		500 Hz	35	46	44	51	37	50	47	53
		1 kHz	33	40	40	45	36	42	42	47
		2 kHz	33	37	38	40	35	39	40	42
		4 kHz	33	36	36	38	35	38	38	39
		8 kHz	33	36	36	37	36	37	38	37
	Lw (A) (dB(A))	39	46	50	54	43	46	50	53	
	$p_s = 125$ Pa	Lw (dB/Oct)	63 Hz	43	49	52	61	46	51	56
125 Hz			44	56	60	64	45	59	64	69
250 Hz			44	55	58	62	44	55	59	64
500 Hz			42	51	56	59	42	51	57	59
1 kHz			39	47	50	42	41	48	53	53
2 kHz			38	45	48	49	38	45	48	49
4 kHz			37	43	48	48	38	44	47	48
8 kHz			37	42	45	52	36	40	41	46
Lw (A) (dB(A))	45	52	56	58	49	54	57	59		
$p_s = 125$ Pa	Lw (dB/Oct)	63 Hz	48	52	60	62	53	58	66	69
		125 Hz	48	60	70	72	50	63	70	73
		250 Hz	48	59	67	68	47	60	68	69
		500 Hz	46	57	62	63	46	57	62	64
		1 kHz	44	55	57	58	46	54	56	58
		2 kHz	44	52	54	56	44	53	56	58
		4 kHz	42	48	50	54	43	48	51	55
		8 kHz	41	46	49	51	43	48	51	53
Lw (A) (dB(A))	50	58	60	62	52	58	61	64		
$p_s = 125$ Pa	Lw (dB/Oct)	63 Hz	60	64	70	74	60	64	70	74
		125 Hz	58	61	70	73	58	63	70	73
		250 Hz	53	60	69	73	55	62	70	73
		500 Hz	52	60	67	72	54	60	67	72
		1 kHz	53	58	66	70	56	59	66	70
		2 kHz	51	57	65	68	55	59	65	69
		4 kHz	50	56	61	65	50	57	61	65
		8 kHz	49	55	60	63	49	57	60	65
Lw (A) (dB(A))	55	64	71	77	60	67	72	79		

Legend:

Q = Air volume in m³/h.

V_k = Average velocity in the damper in m/s.

P_s = Pressure drop over the damper according to the position of the blade in Pa.

Lw (dB/Oct) = Sound power given at a specific pressure drop (P_s) for the frequencies from 63 Hz up to 8 kHz in dB.



ACDPH

Circular motorised damper with pressure control

Wiring diagram

RJ45 socket (Power over Modbus)

Pin 1	24 VDC	Supply voltage, 24 VDC
Pin 2		
Pin 3	A	Modbus RTU communication, signal A
Pin 4		
Pin 5	/B	Modbus RTU communication, signal /B
Pin 6		
Pin 7	GND	Power over Modbus supply, 24 VDC
Pin 8		



Terminal block

VIN	Supply voltage, 24 VDC
GND	Supply voltage, ground
A	Modbus RTU communication, signal A
/B	Modbus RTU communication, signal /B

Attention! The damper needs to be supplied via the RJ45 connector or via the terminal block. Do not connect supply voltage via both simultaneously.

Standards



- Machinery Directive 2006/42/EU:
 - EN 1751 Ventilation for buildings - Air terminal devices - Aerodynamic testing of damper and valves
 - EN 16798-3:2017 Energy performance of buildings - Ventilation for buildings - Part 3: For non-residential buildings - Performance requirements for ventilation and room-conditioning systems (Modules M5-1, M5-4)
- Low voltage (LVD) directive 2014/35/EU:
 - EN 60730-1:2011 Automatic electrical controls for household and similar use - Part 1: General requirements
 - EN 60730-2-14:1997 Automatic electrical controls for household and similar use - Part 2-14: Particular requirements for electric actuators Amendments A1:2001, A11:2005 and A2:2008 to EN 60730-2-14
- Electromagnetic compatibility (EMC) directive 2014/30/EU:
 - EN 61000-6-2:2005 Electromagnetic compatibility (EMC) — Part 6-2: Generic standards — Immunity for industrial environments Amendment AC:2005 to EN 61000-6-2
 - EN 61000-6-3:2007 Electromagnetic compatibility (EMC) — Part 6-3: Generic standards — Emission standard for residential, commercial and light-industrial environments Amendments A1:2011 and AC:2012 to EN 61000-6-3
- RoHS Directive (2011/65/EU)
 - EN IEC 63000:2018 Technical documentation for the assessment of electrical and electronic products with respect to the restriction of hazardous substances

Global trade item numbers (GTIN)

Packaging	
ACDPH-125 (unit)	05401003018637
ACDPH-160 (unit)	05401003018781

Fixing and dimensions

ACDPH-125

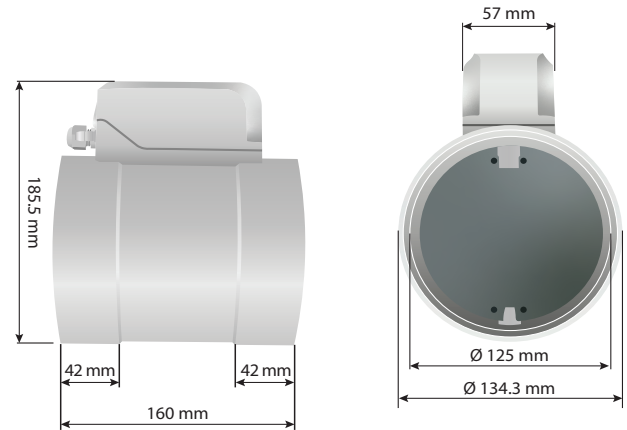

ACDPH-160

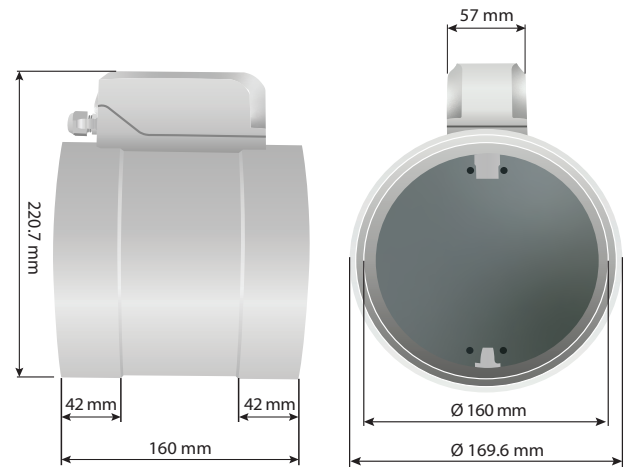

Packaging

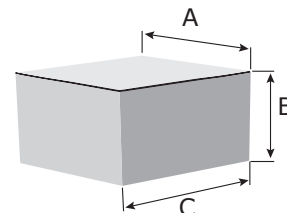

Article	Packaging	A [mm]	B [mm]	C [mm]	Net weight	Gross weight
ACDPH-125	Unit (1 pc.)	230	185	175	0,62 kg	0,90 kg
ACDPH-160	Unit (1 pc.)	230	185	175	0,64 kg	0,92 kg