

! Consult the external product manufacturers for the correct wiring.
First connect the products, then download the firmware for this solution ID via SenteraWeb.
The firmware will be automatically downloaded in the connected device(s).

Sentera products		External products
Article codes		
1) DRPS8-24-40	7) DIG-M-2	13) AC fan
2) DIO-M-D4	8) MDB-M-6	14) Supply air damper actuator
3) DRPUM	9) ODTM	15) Electric heater
4) DMDBM22	10) DSTHM-2	
5) HPS-M-1K0-2 (PSET-PVC-200)	11) ADPT-3SM-FI	
6) HPS-M-1K0-2 (PSET-PVC-200)	12) FI-E44095E2	

This document is to be treated as an example or guideline only.
Sentera bears no responsibility for any misprints, misinterpretations or mistakes in this document.
Consult our disclaimer on <https://www.sentera.eu/>

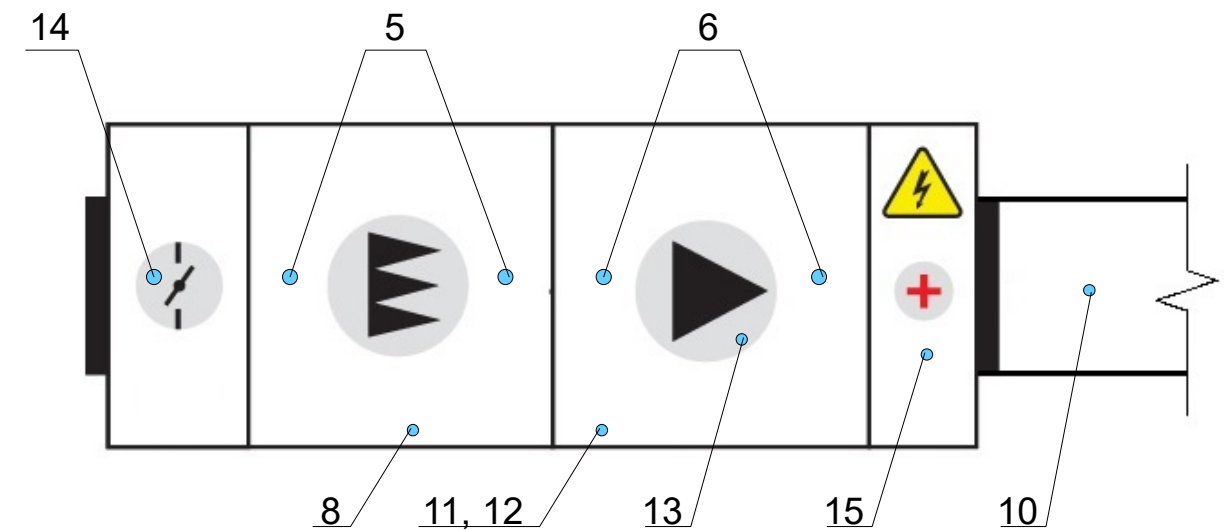
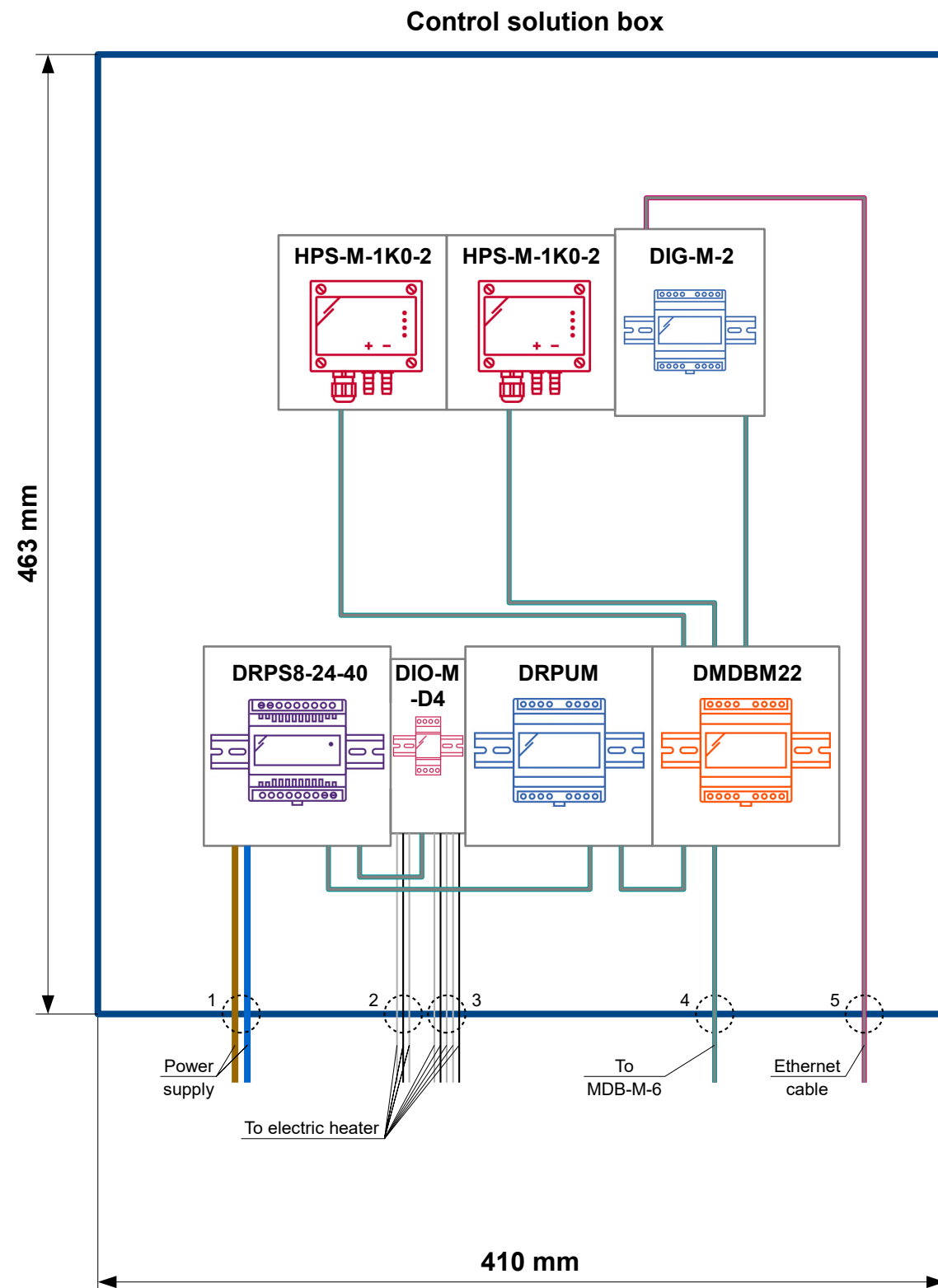

AHU overview with control and measuring equipment

! Consult the external product manufacturers for the correct wiring.
First connect the products, then download the firmware for this solution ID via SenteraWeb.
The firmware will be automatically downloaded in the connected device(s).

Sentera products		External products
Article codes		
1) DRPS8-24-40	7) DIG-M-2	13) AC fan
2) DIO-M-D4	8) MDB-M-6	14) Supply air damper actuator
3) DRPUM	9) ODTM	15) Electric heater
4) DMDBM22	10) DSTHM-2	
5) HPS-M-1K0-2 (PSET-PVC-200)	11) ADPT-3SM-FI	
6) HPS-M-1K0-2 (PSET-PVC-200)	12) FI-E44095E2	

This document is to be treated as an example or guideline only.
Sentera bears no responsibility for any misprints, misinterpretations or mistakes in this document.
Consult our disclaimer on <https://www.sentera.eu/>

Additional product mounting guidelines and explanations

<p>ODTHM The outside temperature sensor must be located on the wall of the house or building, but preferably not directly exposed to the sun. In case of doubt, it should be mounted on the wall facing north or north-west. Preferably in the middle of the house or building or heating zone, but at least 1.5m above the ground. To protect this sensor from too bright sun, rain or snow, use a special cover cap (AWP-10-13-13). Please, avoid following locations: above windows, doors or other places where direct air circulation occurs; air exhaust or other heat sources; below balconies or the eave of the roof.</p>	<p>FI-E44095E2 The frequency inverter should be mounted in a vertical position only, ensuring it is securely placed on a flat, flame-resistant surface that is free from vibrations. Utilize the integral mounting holes or DIN Rail clip for proper installation. Additionally, it is crucial to provide a consistent flow of clean, moisture-free cooling air to meet the specific cooling requirements of the frequency inverter. This not only prolongs the lifespan of the inverter but also ensures optimal performance under varying conditions. Care should be taken to monitor and maintain the ambient temperature within the permissible limits to prevent any overheating issues. The featured solution implies installation of the frequency inverter in the fan section of the AHU. The advantages of this approach are listed below: Space Optimization. Integration within the AHU saves space by eliminating the need for an additional space in the electrical cabinet, making the overall setup more compact and efficient. Reduced Cable Length. Direct integration within the AHU minimizes cable lengths, decreasing electrical losses and electromagnetic interference, thereby enhancing overall system efficiency. Enhanced Control and Responsiveness. Proximity to the fan motor allows for more precise control, enabling better responsiveness to varying loads and improving energy efficiency by adjusting motor speed accurately. Cost Efficiency. By eliminating the need for an external cabinet and associated components, direct integration might result in cost savings during installation and setup.</p>
<p>HPS-M-1K0-2, PSET-PVC-200 When installing PVC tubes, it's important to ensure proper sealing and secure connections to prevent air leakage, which could affect the accuracy of the pressure measurements. Additionally, the tubes should be installed in a way that minimizes bends and obstructions to maintain a smooth airflow path, ensuring reliable and consistent readings from the differential pressure sensor. Keeping the length of the tube to a minimum is preferable.</p>	<p>Conversely, frequency inverter can be installed in the electrical cabinet, however it presents certain considerations: Heat Dissipation. In an enclosed cabinet, heat dissipation might become a concern, especially if the inverter generates significant heat during operation. Inadequate cooling or ventilation within the cabinet can lead to overheating issues, affecting the inverter's efficiency and lifespan. Vibration and Shock. Vibrations and shocks from other electrical components within the cabinet or external factors can affect the inverter's stability and performance, potentially leading to malfunctions or reduced lifespan. Interference and Noise. The presence of other electrical equipment in the cabinet might introduce electromagnetic interference, causing noise or interference that could affect the inverter's performance and reliability. Complexity in Installation. Integrating the inverter within an electrical cabinet adds complexity to the installation process, requiring proper wiring, cable management, and ensuring compatibility with other components.</p>
<p>DSTHM-2 (air heater) The temperature sensor must be located on the supply ventilation duct. The unit must not be installed in turbulent air zones. Ensure sufficiently long settling zones upstream and downstream of the tapping point. A settling zone consists of a straight section of pipe or duct with no obstructions. Avoid installation near filters, cooling coils, fans, humidifiers, etc. The sensor will achieve the optimal result when the measurement is taken at least 7,5 duct diameters downstream and at least 3 duct diameters upstream from any turns or flow obstructions. To protect this sensor from too bright sun, rain or snow, use a special cover cap (AWP-10-13-13).</p>	<p>Check the data sheets and mounting instructions on the Sentera website for more detailed information.</p>
<p>DIO-M-D4 The input/output module (I/O) is used for Modbus RTU networks. It has 4 digital inputs and 4 digital outputs. The digital outputs are activated via a Modbus RTU. The status of the digital inputs is translated into Modbus RTU registers. Three digital outputs are used to connect power steps of the electric heater, allowing to control its thermal capacity. In most cases the electric heater has two levels of overheating protection. Two digital inputs of DIO-M-D4 are used to connect them.</p>	
<p>ADPT-3SM-FI Adapter to connect Invertek frequency inverter (FI-E and FISE series) to a Sentera Modbus RTU network. The Invertek RS485 communication is converted into Modbus RTU communication. This makes it possible for the Sentera HVAC controllers to control the Invertek frequency inverters via Modbus RTU. This adapter is installed inside the fan section of the AHU, near the frequency inverter.</p>	
<p>MDB-M-6 The distribution box is rated with an IP65 protection level. MDB-M-6 can be mounted on the internal or external wall of the air handling unit. Please note that the additional mounting equipment should be provided by the installer.</p>	

Article code / equipment type	Slave ID
Sentera products	
DIG-M-2	n/a (master device)
DRPUM	2
ODTHM	3
DSTHM-2 (air heater)	4
DIO-M-D4	5
HPS-M-1K0-2 (fan)	6
HPS-M-1K0-2 (filter)	7
FI-E44095E2	8
External products	
Air damper actuator	9

Consult the external product manufacturers for the correct wiring. First connect the products, then download the firmware for this solution ID via SenteraWeb. The firmware will be automatically downloaded in the connected device(s).

Sentera products		External products
Article codes		
1) DRPS8-24-40	7) DIG-M-2	13) AC fan
2) DIO-M-D4	8) MDB-M-6	14) Supply air damper actuator
3) DRPUM	9) ODTHM	15) Electric heater
4) DMDBM22	10) DSTHM-2	
5) HPS-M-1K0-2 (PSET-PVC-200)	11) ADPT-3SM-FI	
6) HPS-M-1K0-2 (PSET-PVC-200)	12) FI-E44095E2	

This document is to be treated as an example or guideline only. Sentera bears no responsibility for any misprints, misinterpretations or mistakes in this document. Consult our disclaimer on <https://www.sentera.eu/>